

Biological Spectroscopy:



Structural and Functional
Studies of Biomolecules

Electromagnetic radiation

- Covers an enormous range of wavelengths (hence energies and frequencies)
- The 2 extremes are: radio-waves at 10^{-1} m and gamma-rays at 10^{-11} m
- The visible light represents only a small range: $4-7 \times 10^{-7}$ m
- When the electromagnetic radiation interacts with the matter 3 phenomena can occur:
 - 1. Scattering:** the sky is blue because fluctuating particles of the atmosphere scatter the blue light more than red
 - 2. Absorption:** a piece of glass absorbs the red light and the transmitted light appears blue
 - 3. Emission:** a fluorescent dye may emit green light after absorbing blue light

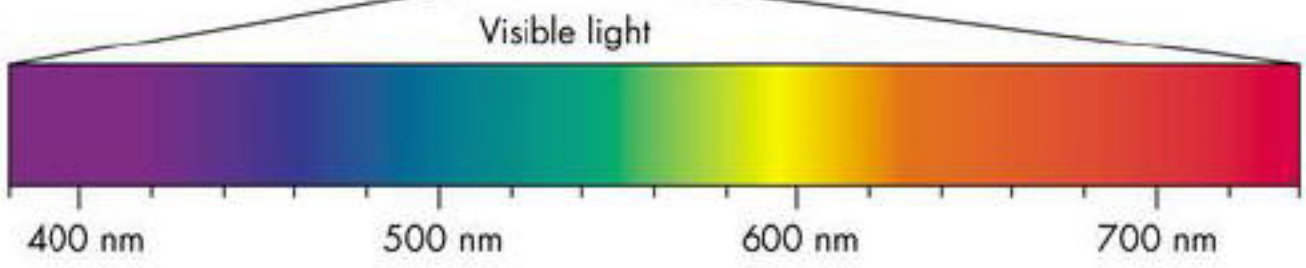
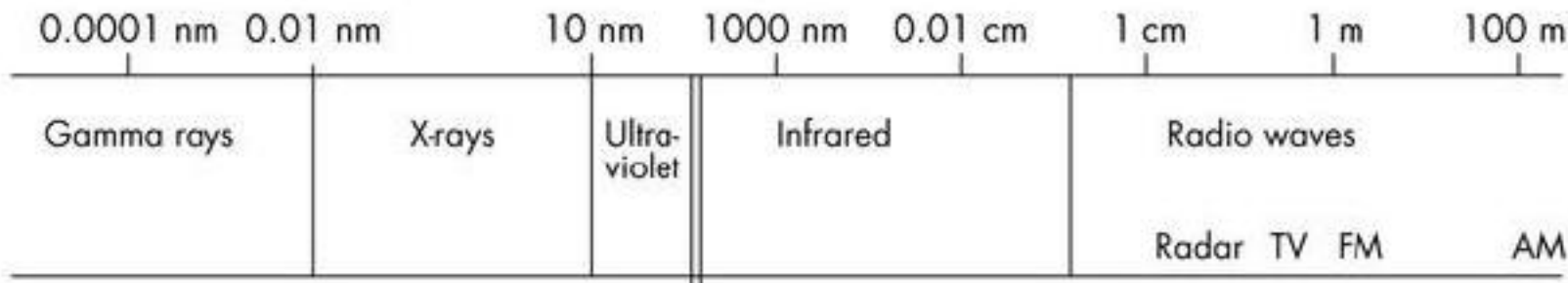
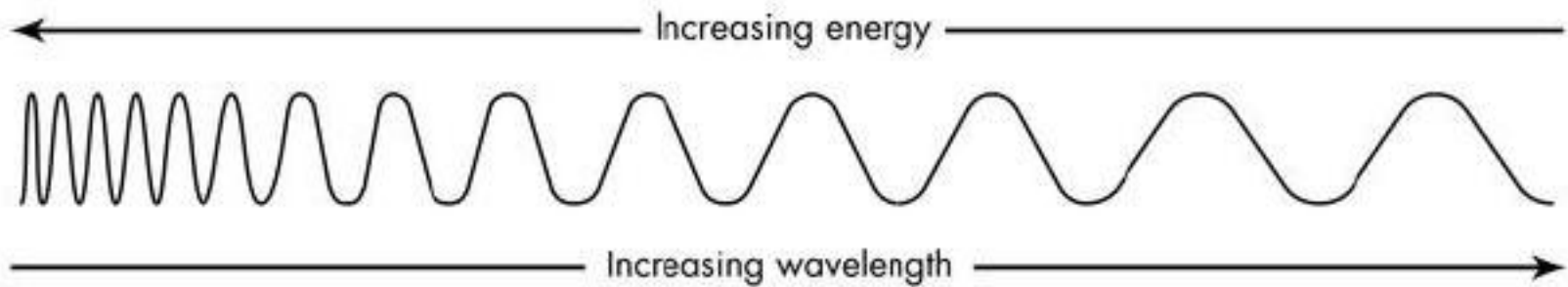

Frequency, wavelength, energy, wavenumber

The *frequency* (ν) and *wavelength* (λ) of a wave are related by the equation

$$\nu = c/\lambda$$

where c is the velocity of propagation of the wave. For electromagnetic radiation in a vacuum, $c = 3 \times 10^8 \text{ m} \cdot \text{s}^{-1}$. Frequency can also be converted directly to units of energy using the relationship $E = h\nu$, where h is Planck's constant ($h = 6.63 \times 10^{-34} \text{ J} \cdot \text{s}$). Units of energy ($\text{J} \cdot \text{mol}^{-1}$), frequency (Hz), and wavelength (m), are all used in discussions of electromagnetic radiation.

Expression of the radiation as a frequency (Hz) gives results with very large numbers; therefore it is common to find, particularly for electromagnetic radiation in the microwave to X-ray range, the frequency expressed as a wavenumber (cm^{-1}). The **wavenumber** (ν') is defined as the inverse of the wavelength in centimeters.

$$\nu' = \frac{1}{\lambda} = \frac{\nu}{c}$$

The wavenumber is thus the number of waves per centimeter.

Spectroscopy

- It studies the interaction of the electromagnetic radiation with the matter, excluding chemical effects
- Spectroscopy studies involve:
 - **Irradiation of the sample**
 - **Measuring the scattering, or absorption or emission**
 - **Interpretation of the results**

The electromagnetic radiation

- It is made of 2 wave motions perpendicular to one another: magnetic wave (M) + electric wave (E)
- In vacuum it propagates at the speed of light $c = 3 \times 10^8 \text{ ms}^{-1}$
- Both M and E have equal energy. A quantitative example for comparison:
 - A 100W bulb generating a light beam of a section of 1 m^2 the energies are E field = 300 Vm^{-1} and B field = 10^{-6} T
 - The Earth's B field = $5 \times 10^{-5} \text{ T}$, a coil of 10 cm radius and 100 turns of wire carrying 1.5 A generates a B = 10^{-3} T at his centre

Figure 2.1 Electromagnetic radiation is made up of two wave motions perpendicular to each other. One is a magnetic (M) wave, the other an electric (E) wave. The waves are propagated along the z-direction.

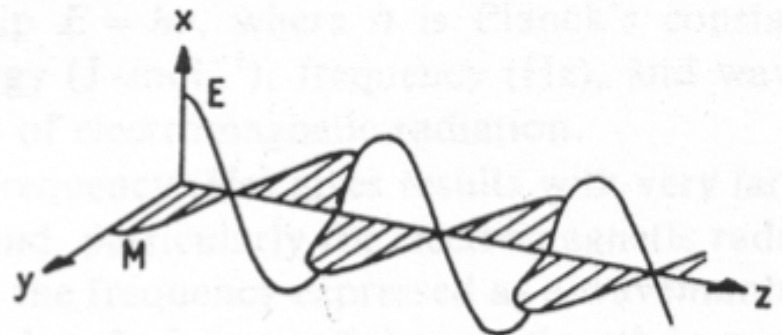

Energy levels

For every *electronic* energy level, there is a set of *vibrational* energy levels:

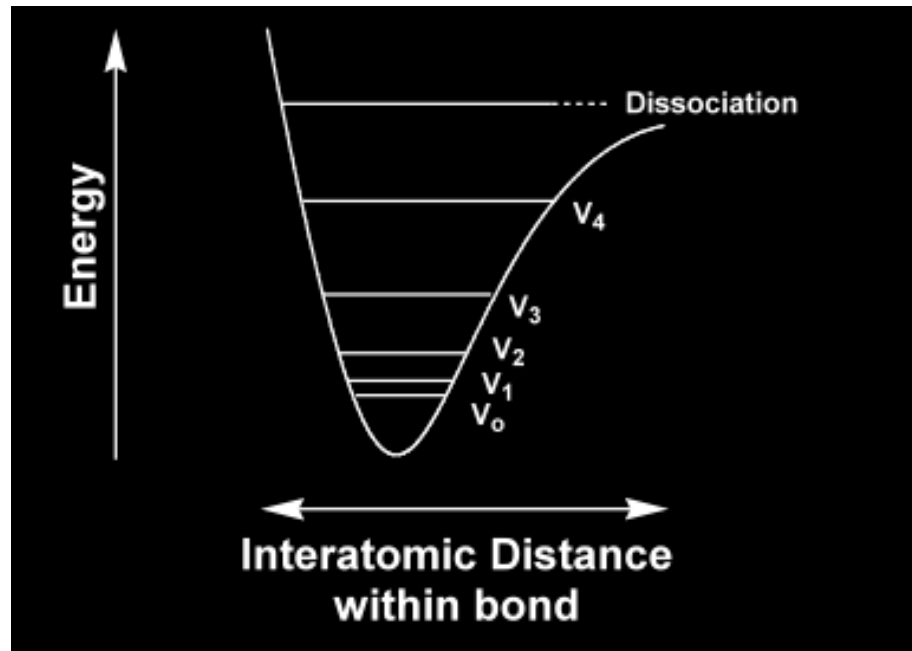

Electronic transitions from the ground state to the excited state

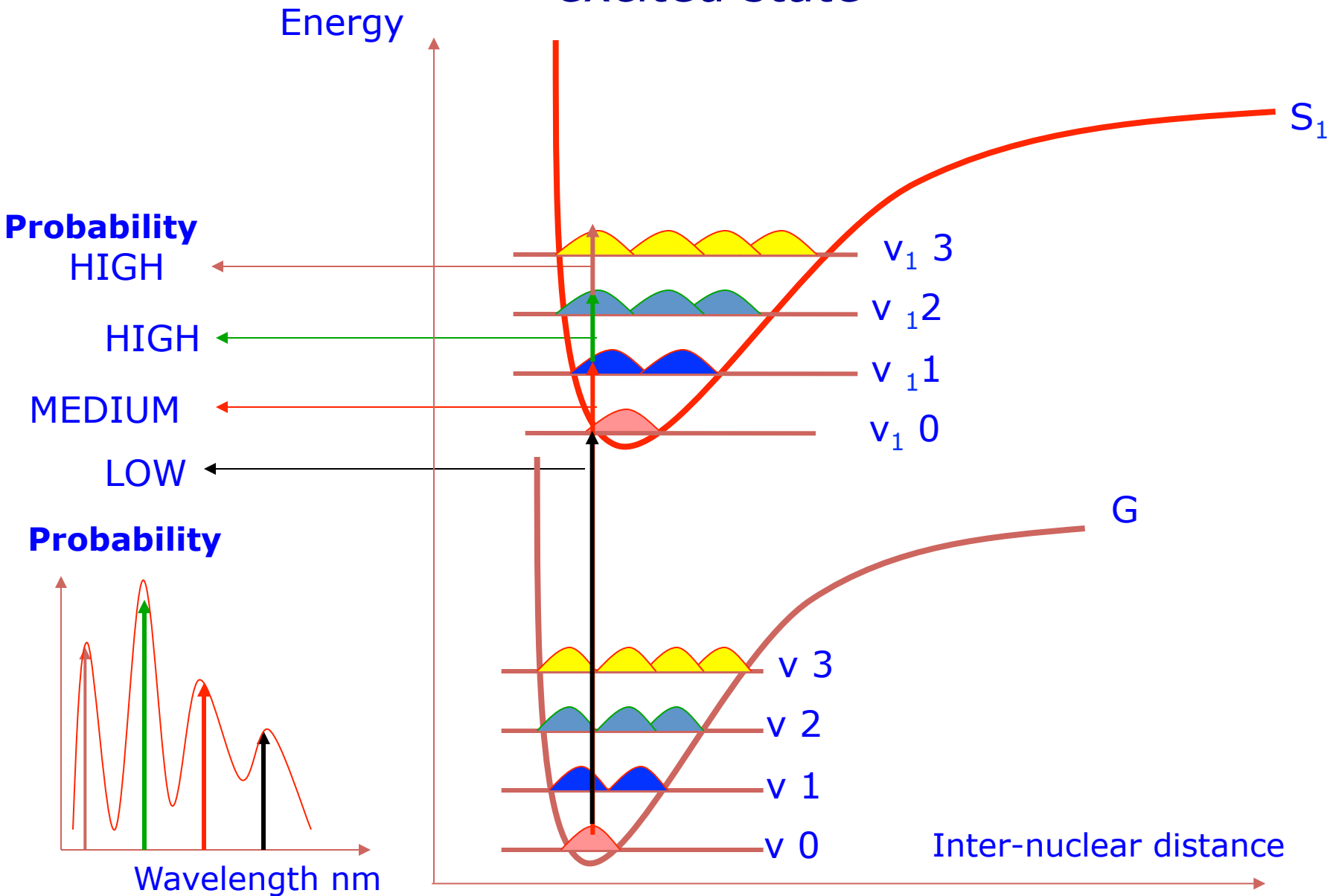

Jablonski Energy Diagram

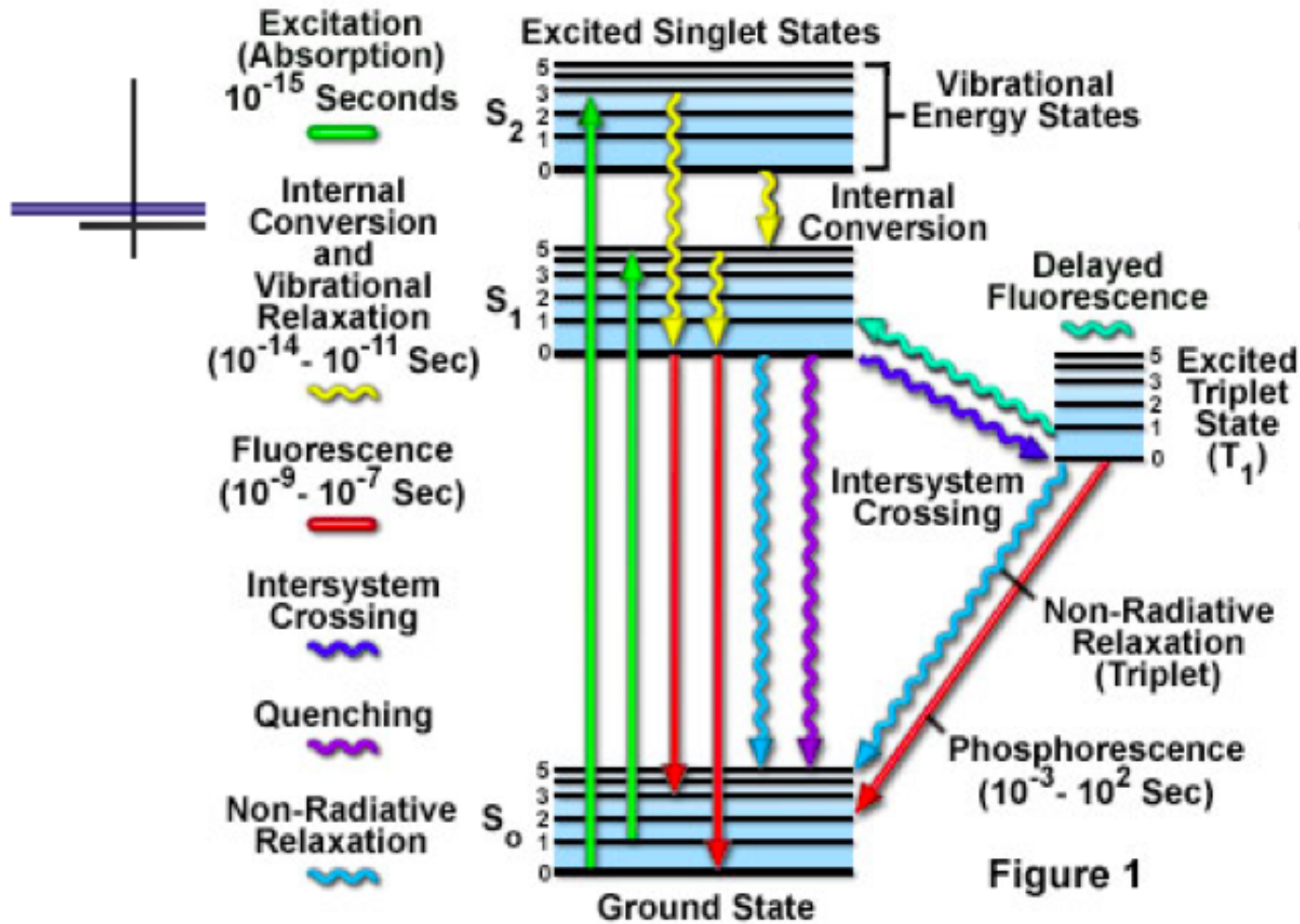

A. Excited States and the Ground State

1. Electrons can move from the ground state to an excited state if energy is supplied, in a *photochemical reaction* this energy is in the form of light
2. The energy difference between electronic energy levels is quantized, so only light of discrete frequencies will cause a transition to occur.

$$E = hn \quad (h = \text{Planck's constant, } n = \text{frequency})$$

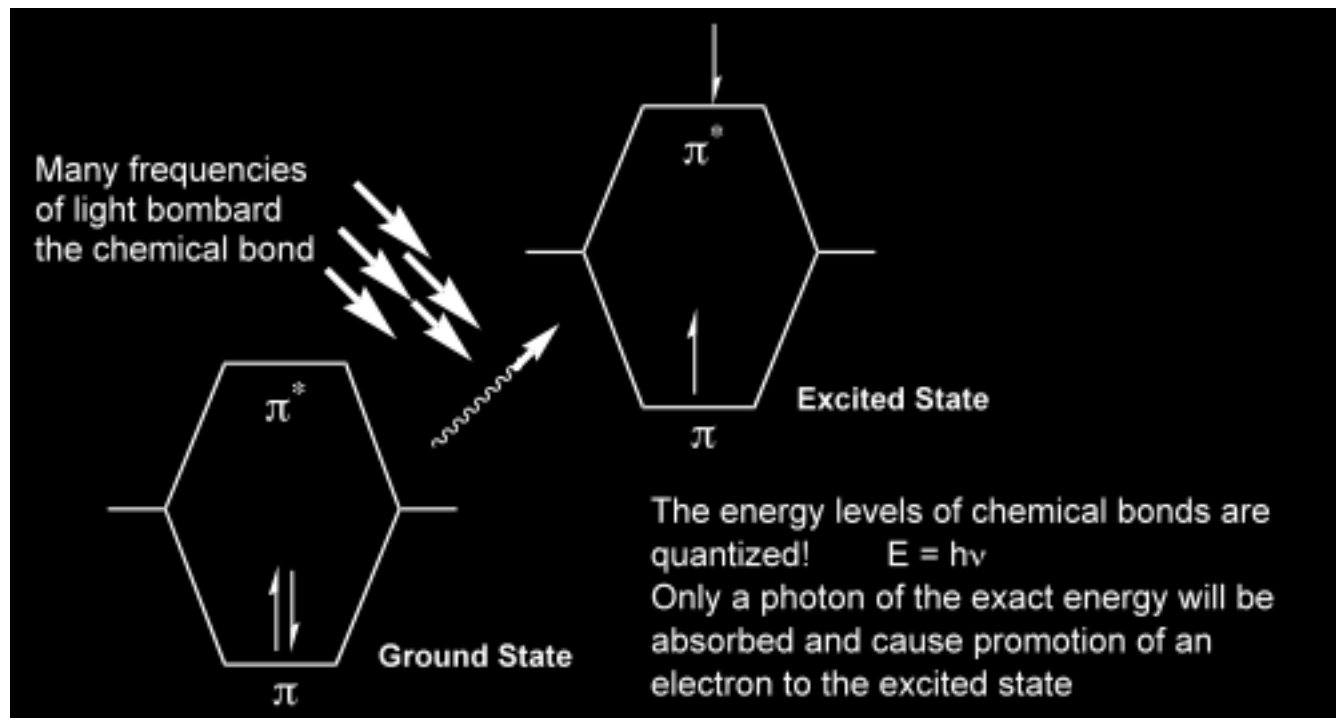

1. The frequencies of light that correspond to the energy difference between electronic energy levels in covalent bonds fall in the visible to ultraviolet region of the spectrum.
2. Functional groups that contain bonds that undergo a given absorption are called *chromophores*

B. Singlet and Triplet States

1. In most organic molecules all electrons in the ground state are paired with each member of the pair possessing an opposite spin (Pauli principle)
2. If one of the electrons is promoted to another orbital of higher energy, the promoted electron is no longer constrained by the Pauli principle and may possess either a parallel or opposite spin to its former partner
3. If a molecule contains two unpaired electrons of the same (or parallel) spin is called a **triplet**
4. If a molecule contains two unpaired electrons of opposite spins it is called a **singlet**

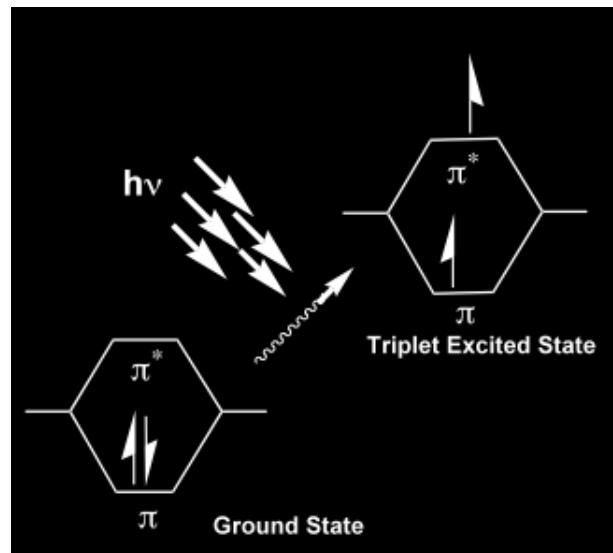
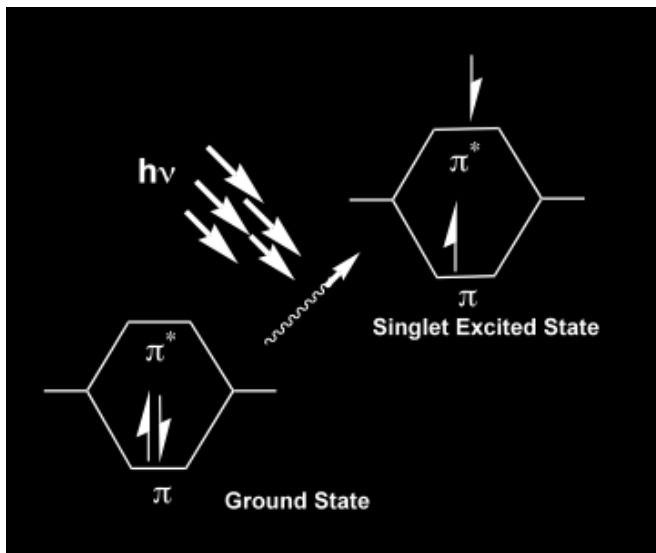

C. Types of Excitation

1. The four possible electronic excitations that are possible (in order of increasing energy):
 1. $\sigma \rightarrow \sigma^*$
 2. $n \rightarrow \sigma^*$ (n denotes an free electrons pairs)
 3. $\pi \rightarrow \pi^*$
 4. $n \rightarrow \pi^*$

“ * ” Denotes an excited state

Absorption maxima : The importance of conjugation

The wavelength value of the **absorption maximum**
and the **molar absorptivity**

are determined by the degree of **Conjugation of π -bonds**

Increasing the number of double bonds shifts the absorption to lower energy

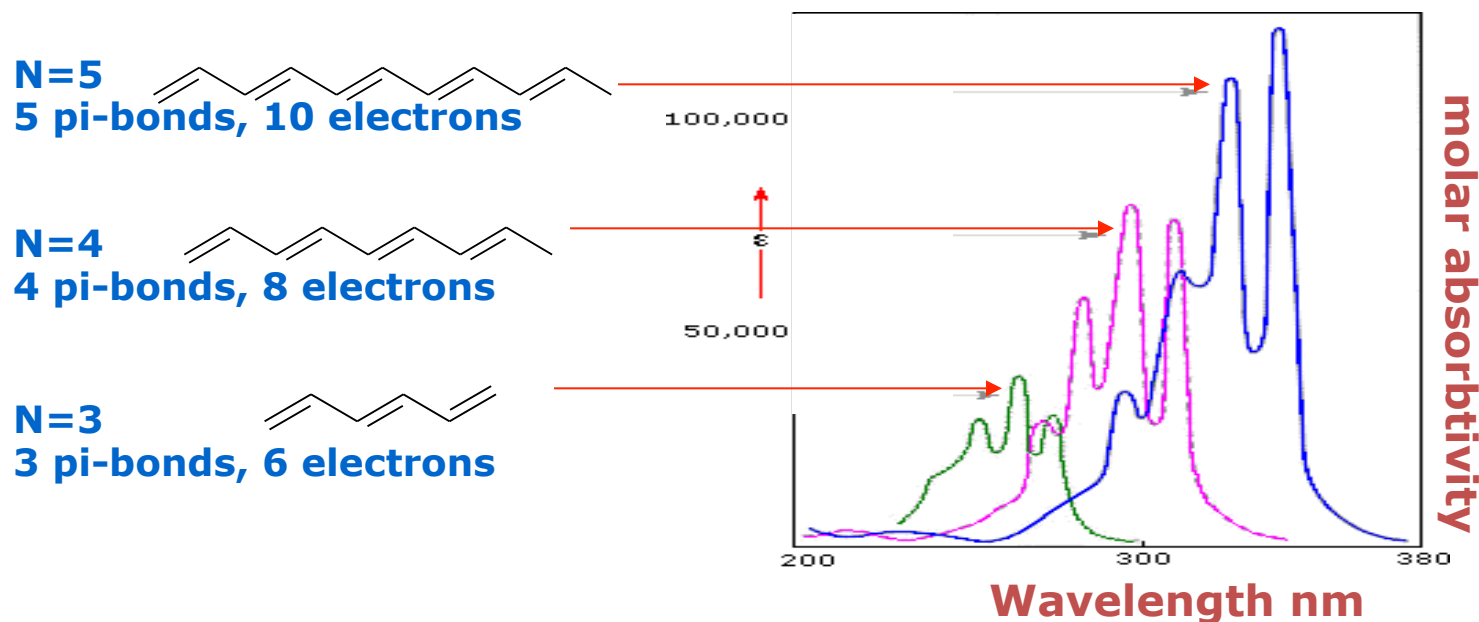

If the double bond is conjugated, delocalization (resonance) causes the electrons within the conjugated system to be lower in energy.

Increasing the number of aromatic rings increases the absorption maximum

Benzene < Naphthalene < Anthracene < naphthacene < pentacene

Abs. Max	262nm	275 nm	375 nm	475 nm	580 nm
Log ϵ (Extinction)	3.84	3.75	3.90	4.05	4.20

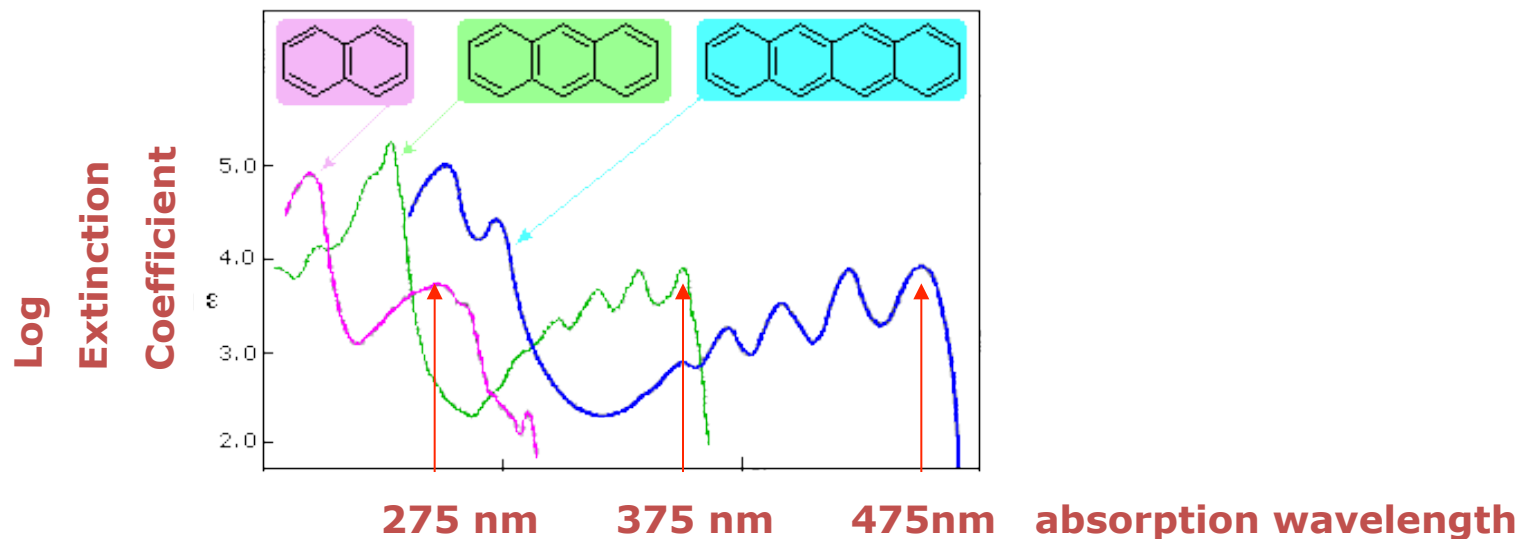

As the **degree of conjugation increases**

(i.e the number of electrons involved in the delocalized π -orbitals)

the **absorption energy decreases** ($> \lambda$, the energy between the ground and excited state decreases)

the **absorption becomes more intense** ($> \epsilon$, increased probability of absorption)

With enough conjugated double bonds, the $\pi \rightarrow \pi^*$ transition will occur in the visible region of the spectrum and perceived as color:

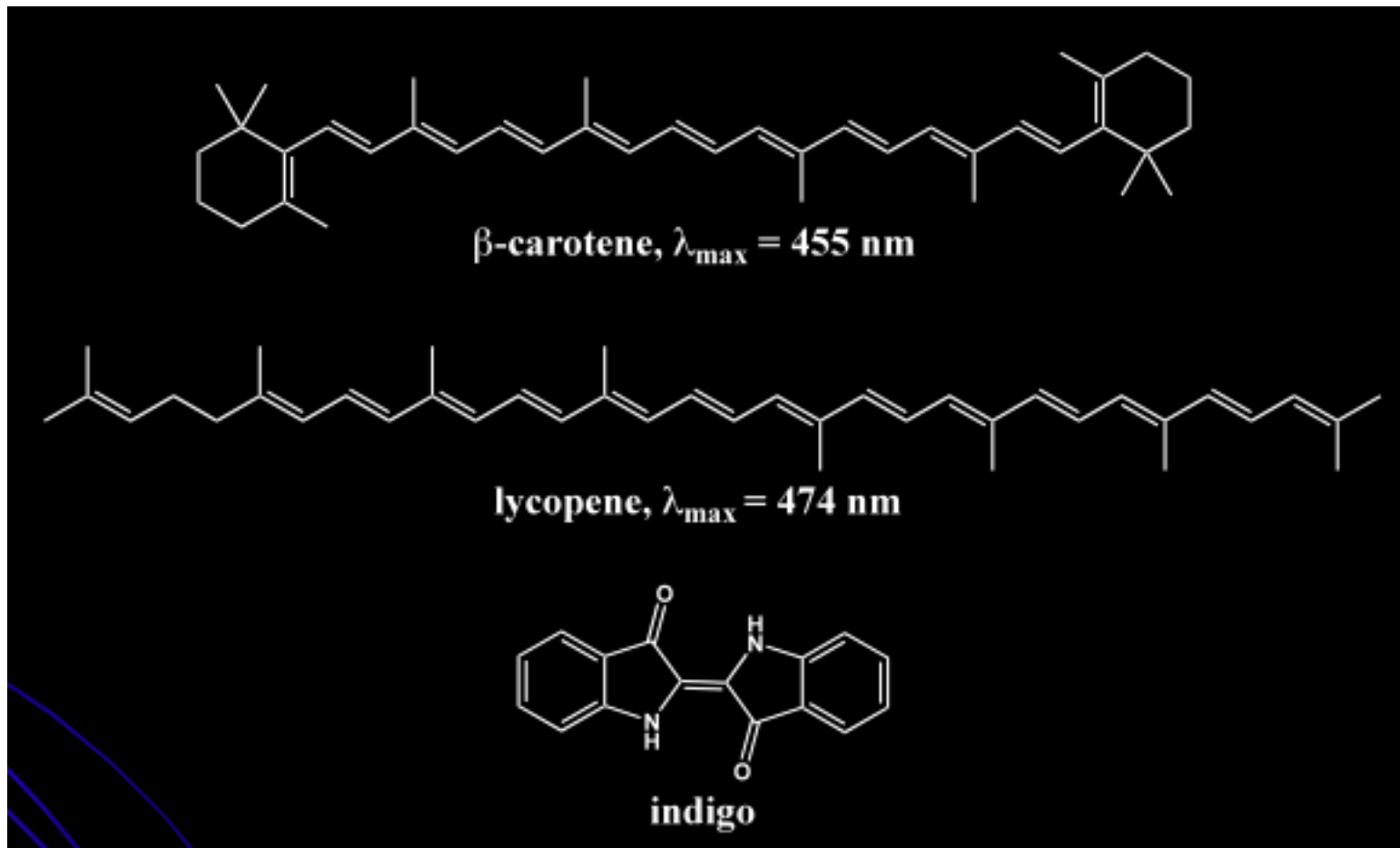

β -carotene from carrots, orange; lycopene from tomatoes, red;
Indigo, the dye used in blue denim; blue

Absorption: measurement

The Beer Lambert Law

$$\text{Absorption (Optical Density)} = \log I_0 / I = \varepsilon c l$$

l is the path length of the sample (1 cm)

- a typical sample: a solution in a cuvette
- the solvent and the reflection from the cuvette walls contribute to the extinction of light
- relative measurement of absorption

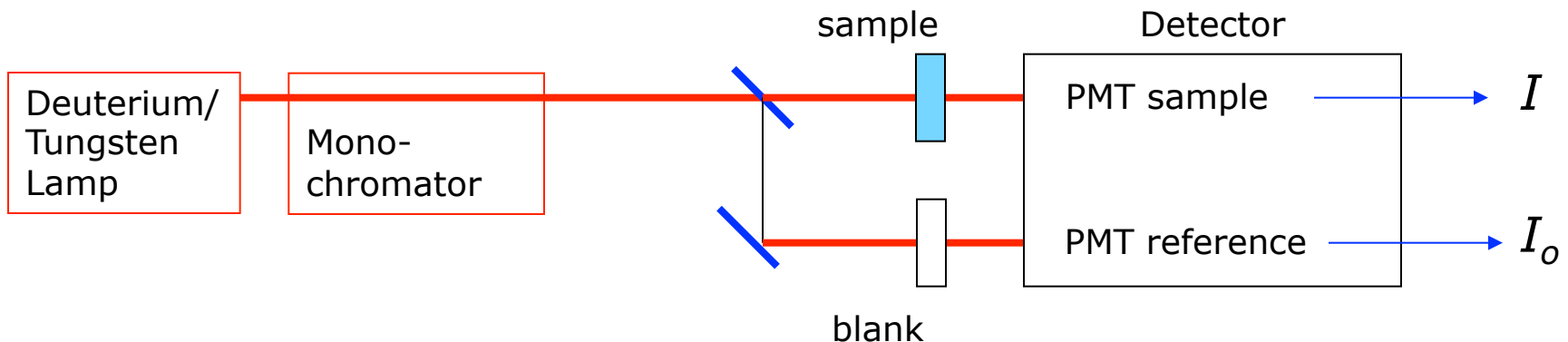
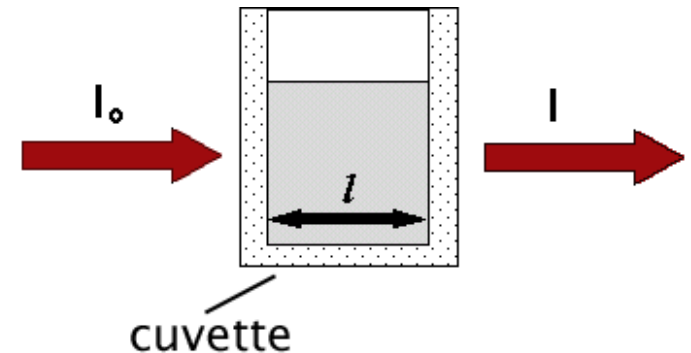

Polarization

- Since the E and M waves always oscillate at 90° it is sufficient to define the E wave
- Non-polarized light the E-wave can oscillate in any plane (xy) perpendicular to the direction of propagation (z)
- Polarized light oscillate only on one plane

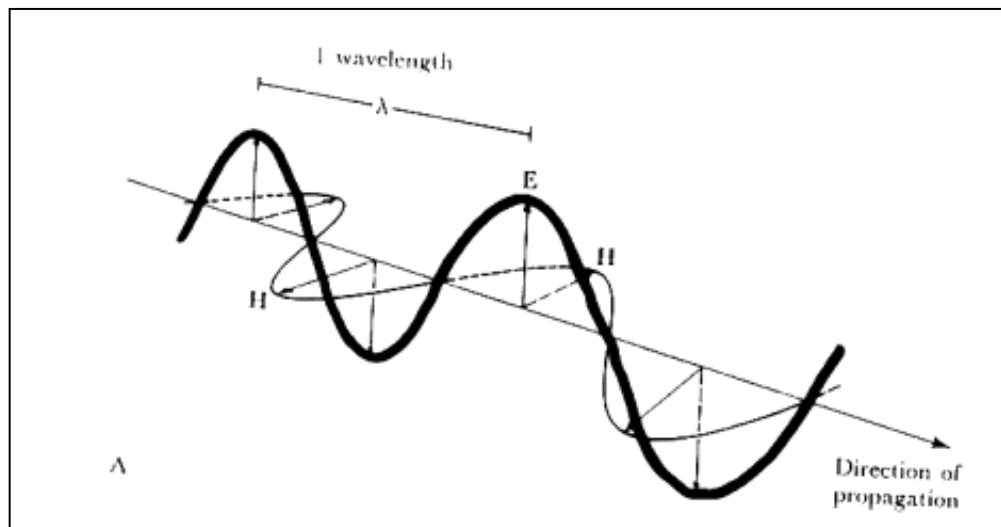

Polarization

- Plane-polarized light like the one of the figure b can be considered to arise from a source that oscillates parallel to the x-axis

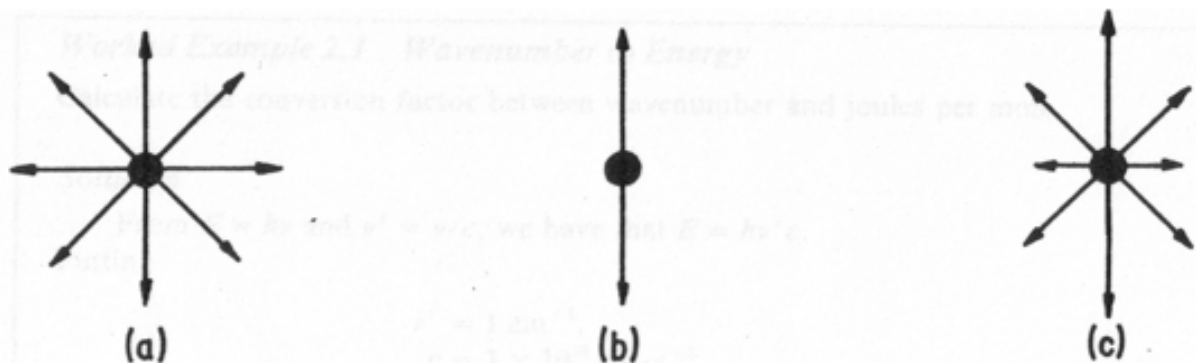
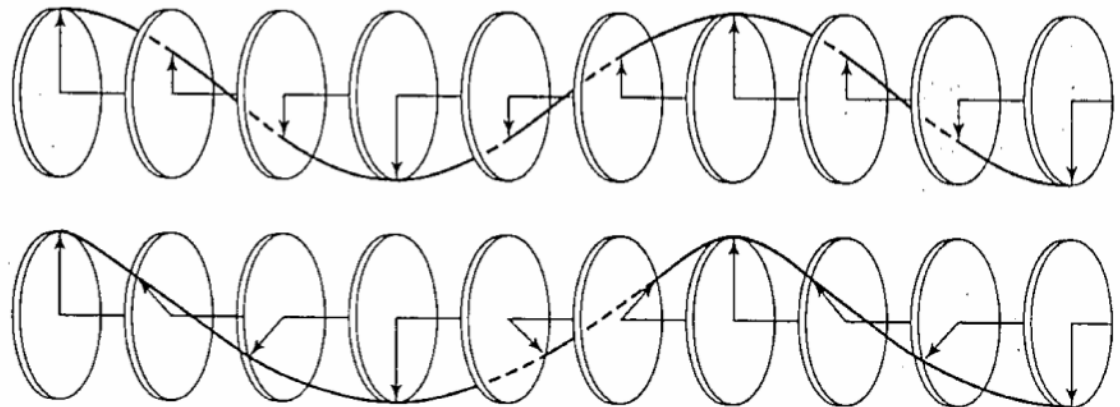
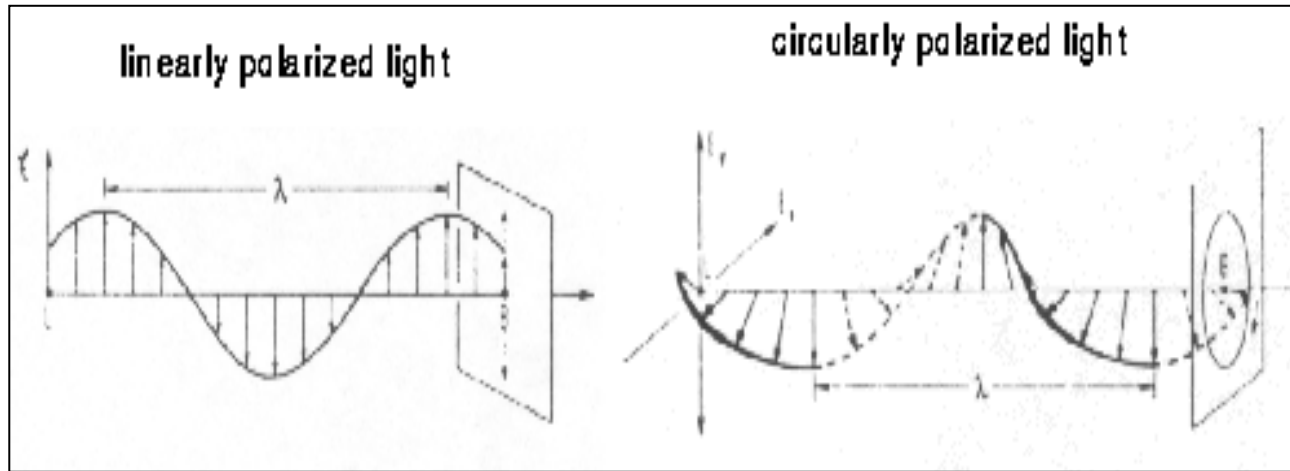

Figure 2.2 Directions of the electric vector in polarized and unpolarized light. In unpolarized light (a), or partly polarized light (c), the oscillations take place at all angles perpendicular to the direction of travel; in polarized light (b) they are restricted to one angle.

CIRCULARLY POLARIZED LIGHT

- It is obtained through the superposition of linearly and perpendicular polarized waves, having the same wavelength and intensity, but different for a quarter phase.
- It can be right-handed or left-handed.



CIRCULARLY POLARIZED LIGHT

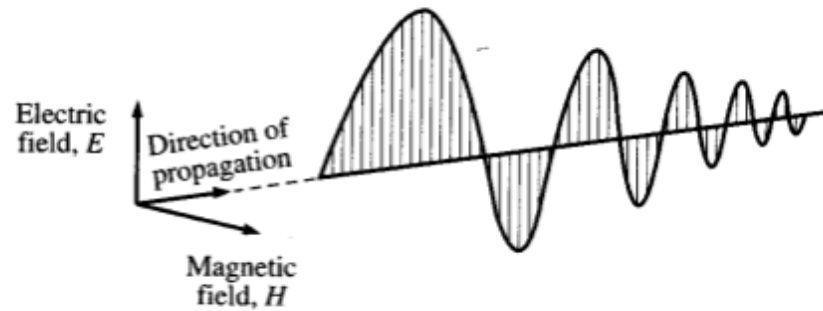
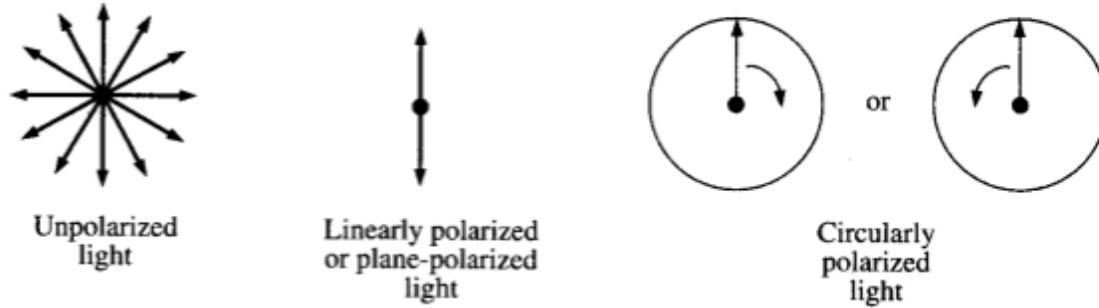

Linearly (or plane-) polarized light

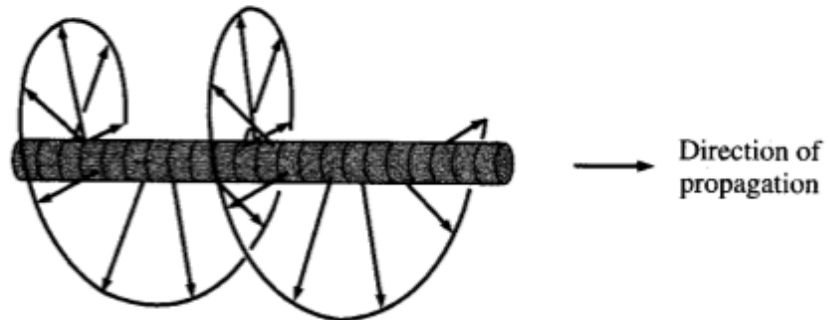

POLARIMETRY

- it is a technique that measures the variation of the angle of the plane of polarized light after the light has passed through a solution containing a chiral (optically active) substance .
- optical isomers, those whose mirror images are non-overlapping (chiral), possess the property of rotating the plane of polarized light. This property is due to the presence of a center of asymmetry in the molecule.

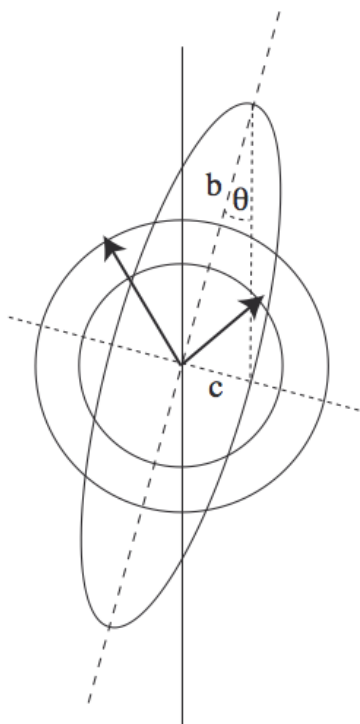

- in substances with optical activity the left and right circularly polarized light beams are traveling at different speed and are absorbed to a different extent.
- the circular dichroism is characterized by the ratio of the semiminor and semimajor axes of the ellipse
$$\tan \theta = c/b$$
- θ is known as the ellipticity

CIRCULAR DICHROISM

- optical isomers absorb the circularly polarized light, but absorb the right- and left-handed components in a different way, giving rise to an elliptically polarized light.

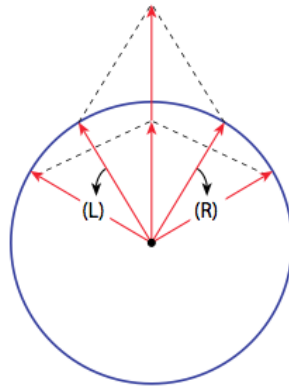

Non-chiral compound. If the 2 components have the same amplitude $E_R = E_L \Rightarrow$ linearly polarized light.

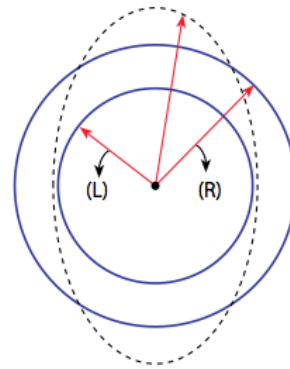

Chiral compound. If the 2 components have different amplitude, $E_R \neq E_L \Rightarrow$ elliptically polarized light, that is, the tip of the resultant vector trace an ellipse (dotted line).

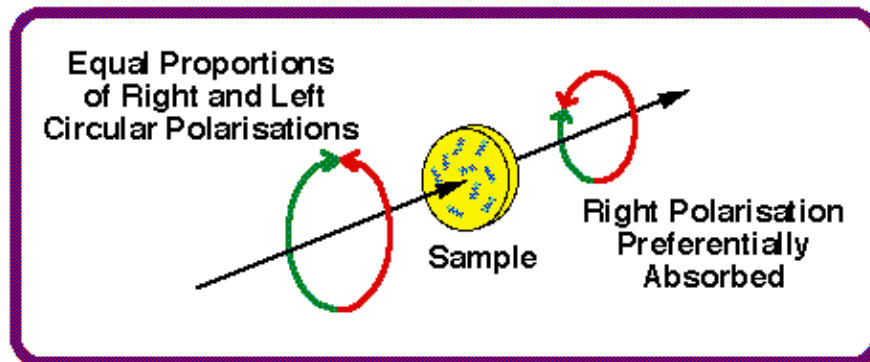

DETERMINATION OF THE SECONDARY STRUCTURE OF BIOPOLYMERS: FAR UV CD

PROTEINS.

- Peptide bond(far-UV)

$n \rightarrow \pi^*$ centered around 220 nm

$\pi \rightarrow \pi^*$ centered around 190 nm

- The intensity and the energies of these transitions depend on ϕ e ψ , that is the secondary structure.

- Aromatic amino acids(Phe, Tyr e Trp) (near-UV)

- 250-290 nm.

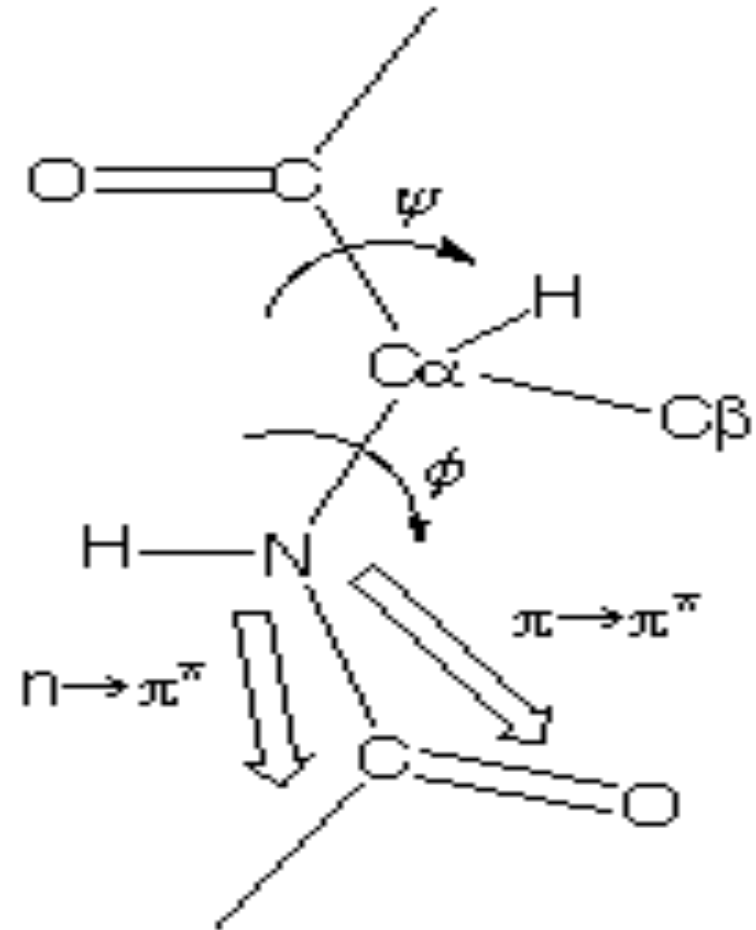

DETERMINATION OF THE SECONDARY STRUCTURE OF BIOPOLYMERS: FAR UV CD

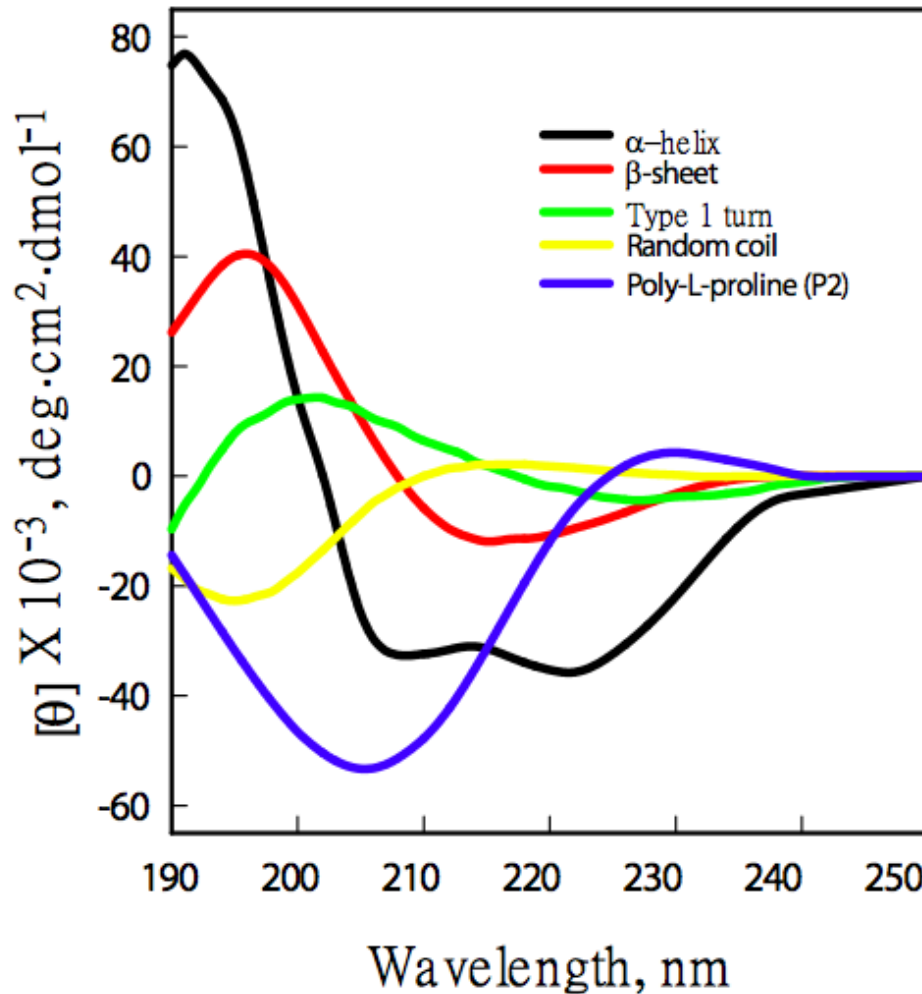

Accuracy of the CD method
(compared to known structures):
helix 95-100%
sheet < 75%
turn < 25%
other < 90 %

DETERMINATION OF THE SECONDARY STRUCTURE OF BIOPOLYMERS: FAR UV CD

<i>Secondary structure element</i>	<i>Signal</i>	<i>Electron transition</i>	<i>Position of minimum or maximum</i>	<i>Molar ellipticity of minima and maxima</i> [deg·cm ² dmol ⁻¹]
α-helix	positive	π->π*	190-195 nm	60.000 to 80.000
	negative	π->π*	208	-36.000 ± 3.000
	negative	n->π*	222	-36.000 ± 3.000
β-sheet	positive	π->π*	195 - 200	30.000 to 50.000
	negative	n->π*	215 - 220	-10.000 to -20.000
random	negative	π->π*	ca. 200	-20.000
	positive	n->π*	220	

Far UV circular dichroism of proteins

Example: denaturation of cytochrome c for heme removal.

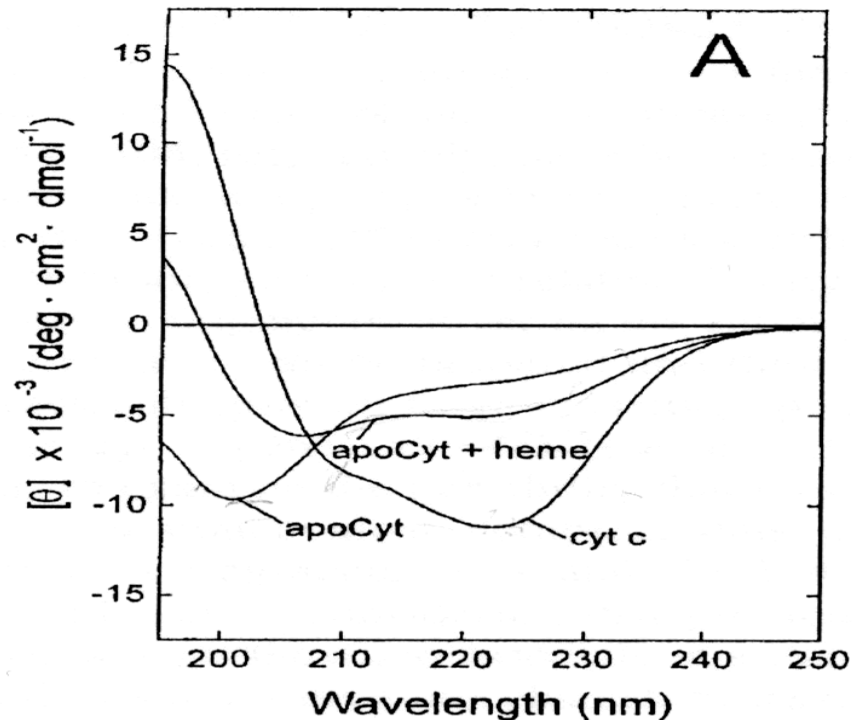

The removal heme from cytochrome c causes the collapse of the secondary structure of the protein. The addition of heme to the apoform causes the refolding of the protein in a conformation different from that of the native protein.

Far UV circular dichroism of proteins

Example: Thermal denaturation of a bacterial oxygenase.

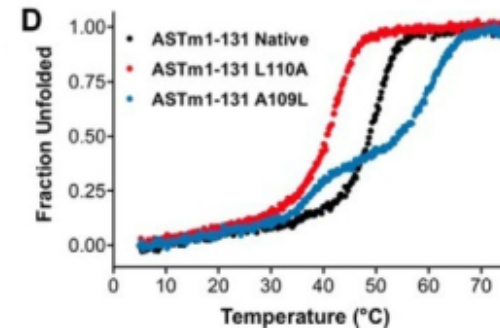
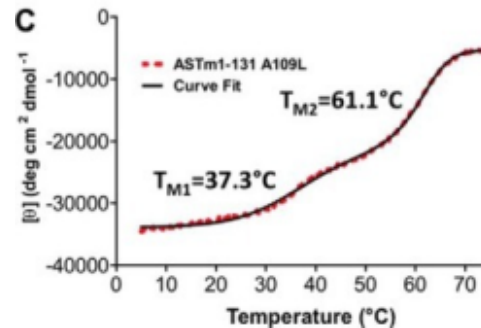
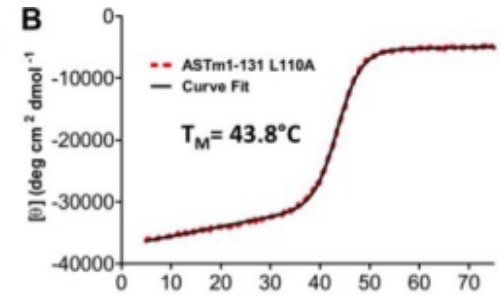
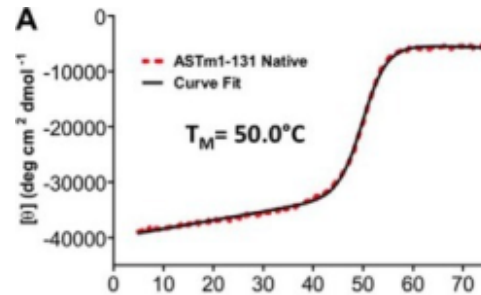
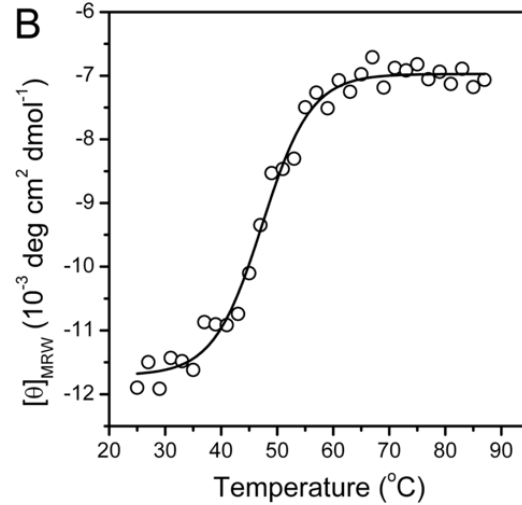
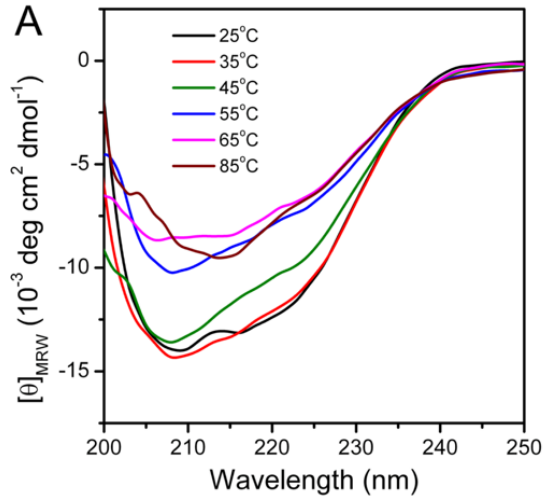

Near UV circular dichroism of proteins

The **near UV CD** spectrum for type II dehydroquinase from *Streptomyces coelicolor*. The wavelength ranges corresponding to signals from Phe, Tyr and Trp side chains are indicated, but it should be emphasized that there can be considerable overlap between the Tyr and Trp signals.

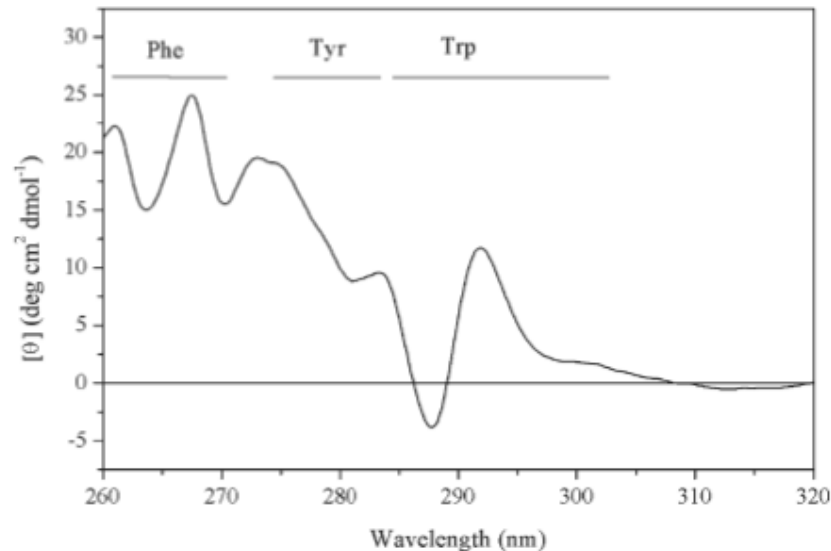

Near UV circular dichroism of proteins

Factors that influence the signal intensities of aromatic residues:

- 1) Rigidity of the protein: the higher the mobility of the polypeptide chain, the lower the signal strength.
 - 2) Interactions between the various aromatic amino acids, which are very significant if the distances between them are less than 1 nm.
 - 3) Number of aromatic amino acids present in the sequence.
- The contribution of each amino acid to the CD spectrum can be studied using site-directed mutagenesis.
 - An aromatic amino acid at a time is mutated and changes in the CD spectrum observed.

Near UV circular dichroism of proteins

pH-Induced denaturation of natively folded HuIL-1 β

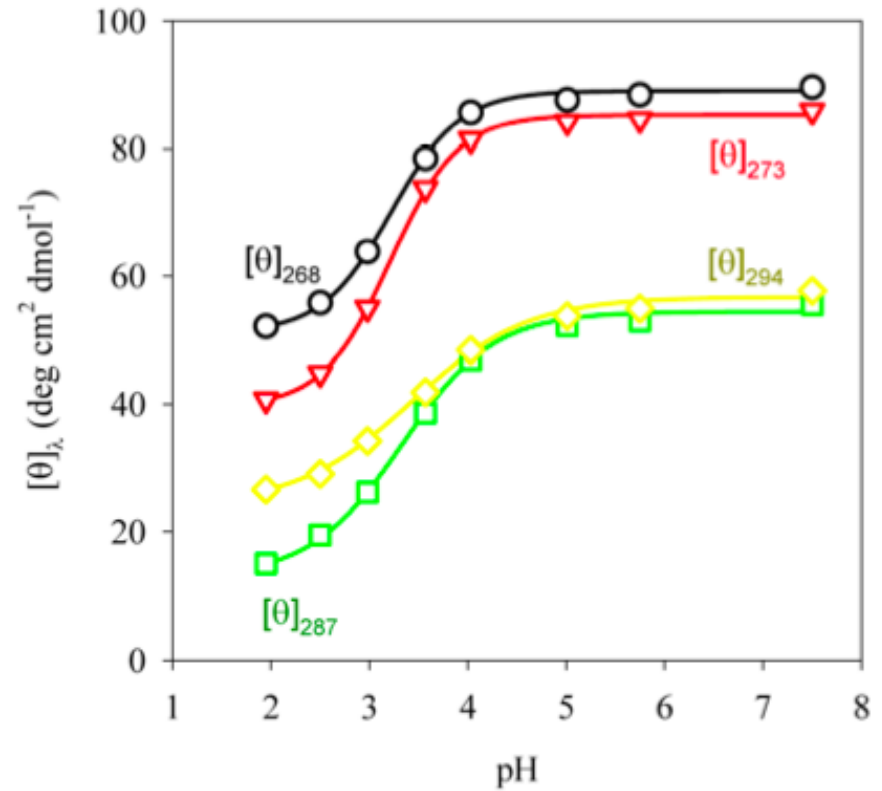
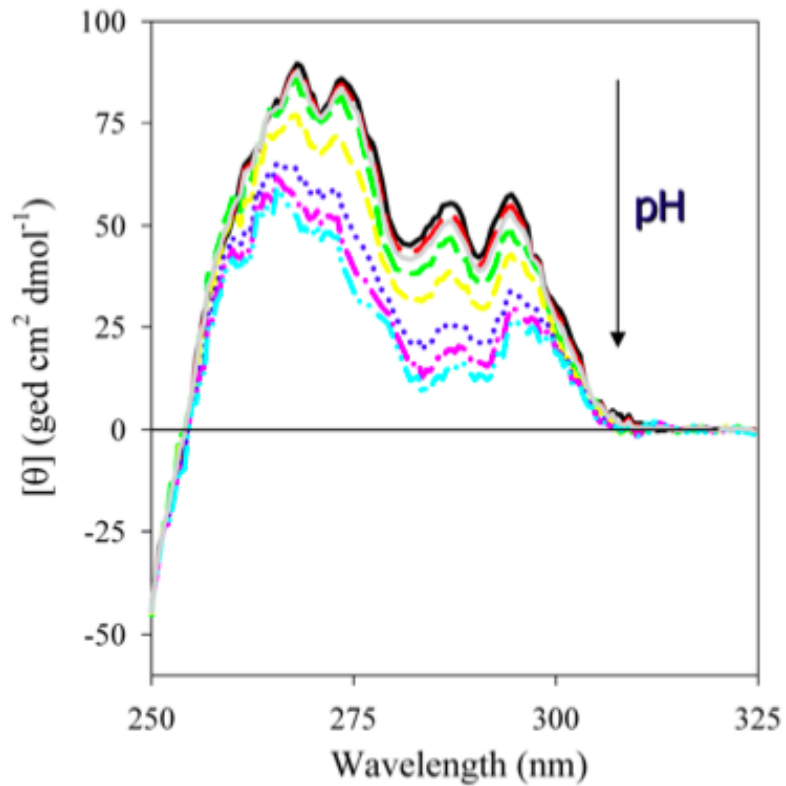

Visible CD.

In many cases the cofactor of a protein is not of itself optically active, but it becomes so by binding with the protein, as this makes an asymmetrical around.

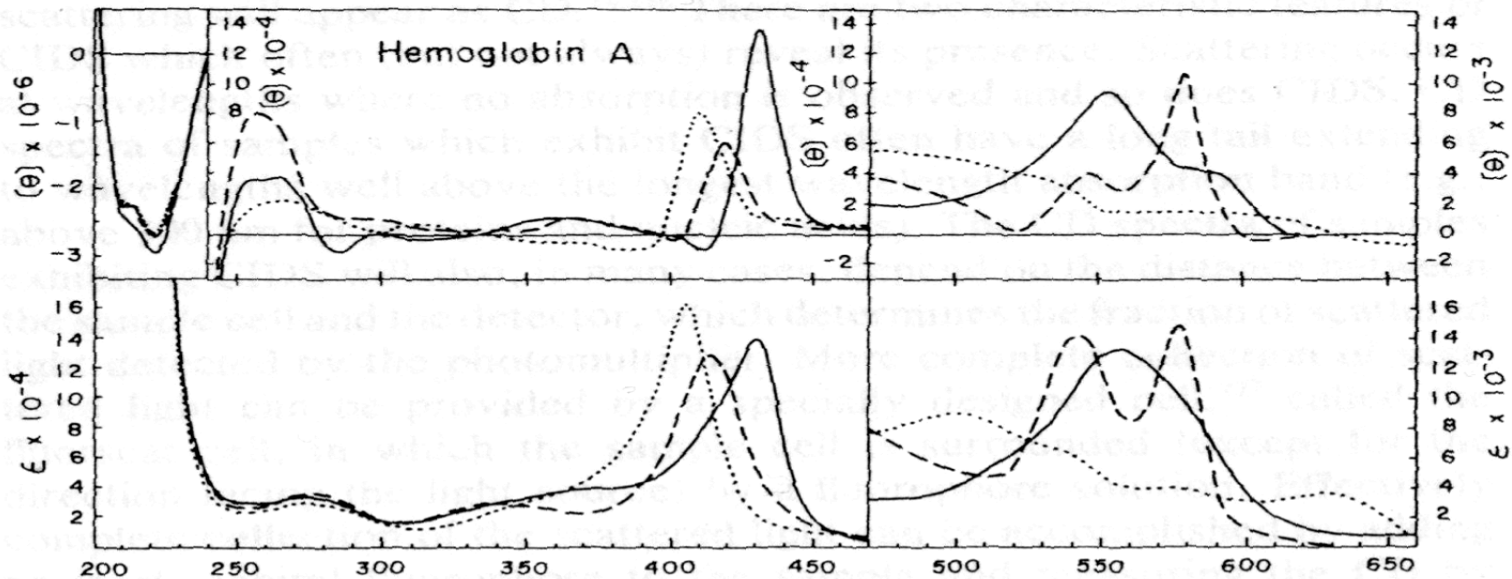

Human hemoglobin

----- oxihb

————— deoxyHb

..... methHb

Fluorescence : the basis

- Fluorescence involves two processes:
 - Absorption
 - Emission
- Each process occurs in the timescale given by the inverse of the transition frequency:
 - Absorption occurs in the 10^{-15} s
 - Excited state occurs in the 10^{-9} s
- The lifetime of a molecule in the excited state depends on competition between radiative emission and any non-radiative process, for example the transfer of energy to the surrounding medium
 - The non-radiative processes relax back the molecule resulting in a diminution of the fluorescence emission intensity. This is called **QUENCHING**

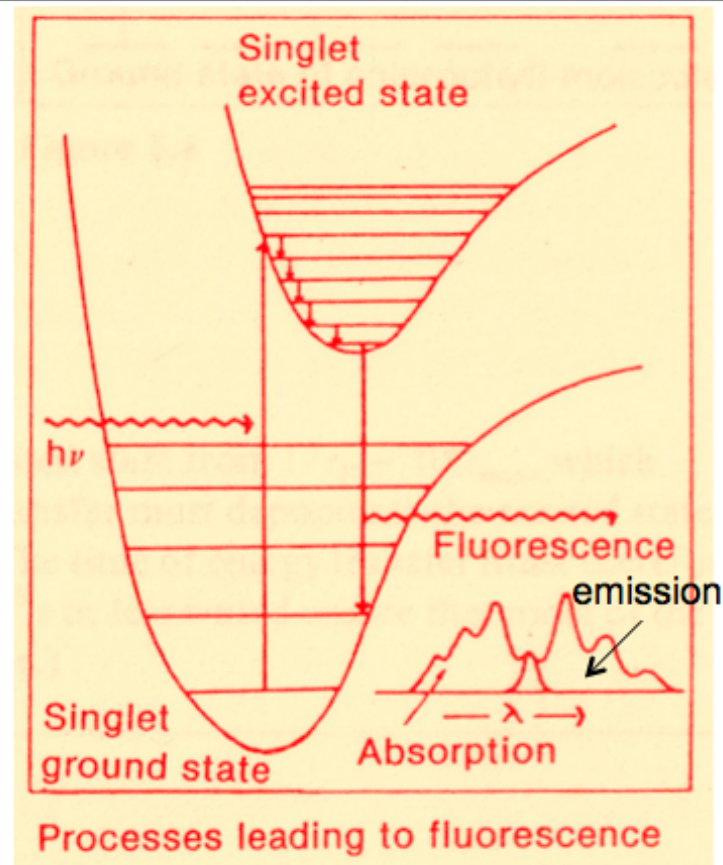

High sensitivity and detection of molecular motions

- The emitted light has a lower energy, that is lower frequency, higher wavelength than that of the incident light
- Because detection of the emission is made at a different wavelength from that of excitation, there is no background signal from the excitation source: this makes fluorescence more sensitive than absorption. Typical concentrations:
 - Absorption: down to 10^{-6} M (microMolar)
 - Fluorescence: down to 10^{-8} M (10 nanoMolar)
- Many reactions, solvent rearrangements, molecular motions take place in the 10^{-9} s, therefore fluorescence can detect these.
 - At the shorter timescale of absorption, 10^{-15} s, the chromophore and its surroundings are essentially static

Fluorescence Intensity

- The fluorescence intensity at a certain wavelength (F_λ) will depend on the initial population of the excited state (I_A) multiplied by the quantum yield (ϕ_F) that is the fluorescence efficiency:

$$F_\lambda = I_A \phi_F$$

- This is true for all the fluorescence emitted in all directions
- In practice only a small amount is collected by the fluorimeter. Therefore this equation must be multiplied by a factor Z that depends on the particular instrument.

What fluorescence can measure in proteins:

- 1. Environment
 - 1.1 λ_{\max} max emission peak = position
 - 1.2 ϕ_F quantum yield = height of emission peak
 - 1.3 τ lifetime = emission as a function of time
- 2. Molecular dynamics
 - 2.1 Dynamic quenching – Stern-Volmer eq.
 - 2.2 Static quenching
 - 2.3 Static and dynamic depolarisation
- 3. Distances between fluorophores: resonance energy transfer – Förster eq.

1. Influence of environment:

Main characteristics of fluorophores are :

- **Maximum excitation and emission wavelength** (expressed in nanometers (nm): corresponds to the peak in the excitation and emission spectra (usually one peak each),
- **Quantum yield** : efficiency of the energy transferred from incident light to emitted fluorescence (= number of emitted photons per absorbed photons)
- **Lifetime** (in nanoseconds): duration of the excited state of a fluorophore before returning to its ground state. It refers to the time taken for a population of excited fluorophores to decay
- **Stokes shift**: difference between the max excitation and max emission wavelengths.

1.2 ϕ_F quantum yield = height emission peak

- The height or intensity of the fluorescence emission peak depends on quantum yield:
 - Increase in ϕ_F = increase in fluorescence peak emission
- In general the quantum yield increases as the polarity of the solvent or the environment decreases
- One has to be careful as the fluorescence emission peak can also be affected by
 - Quenching
 - Resonance-energy transfer

Protein intrinsic protein

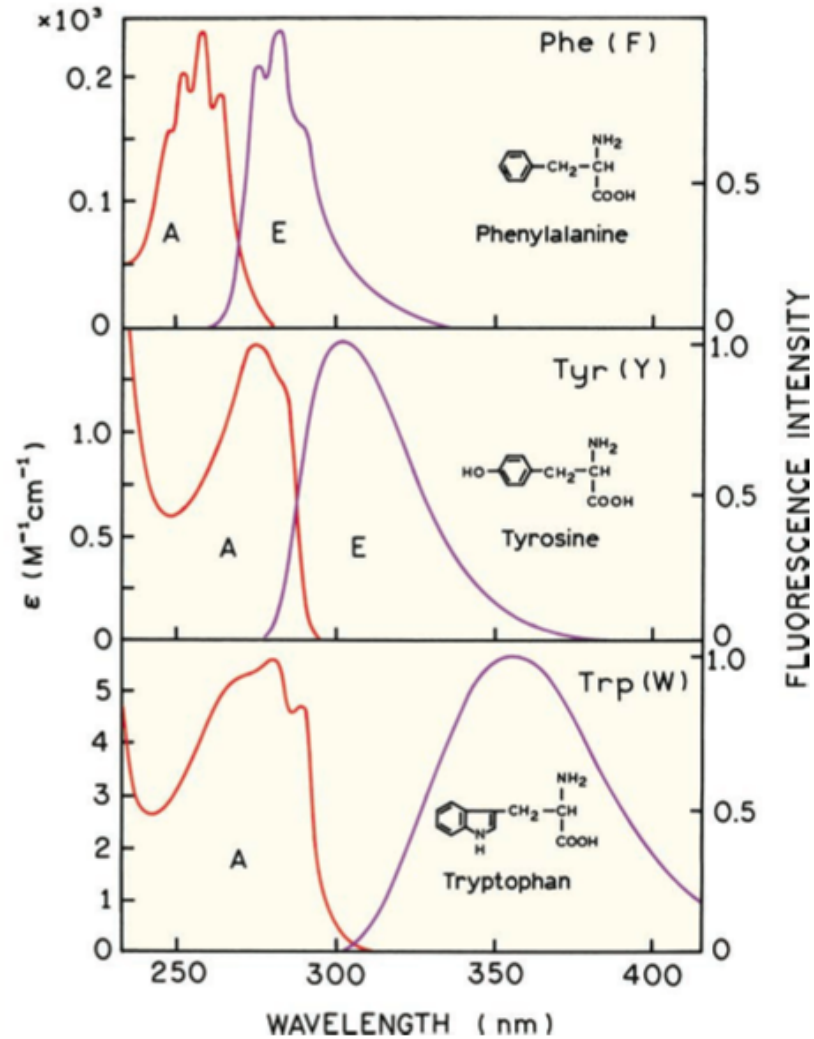

Tryptophan fluorescence differs depending on exposure to solvent
It therefore reports on protein unfolding.

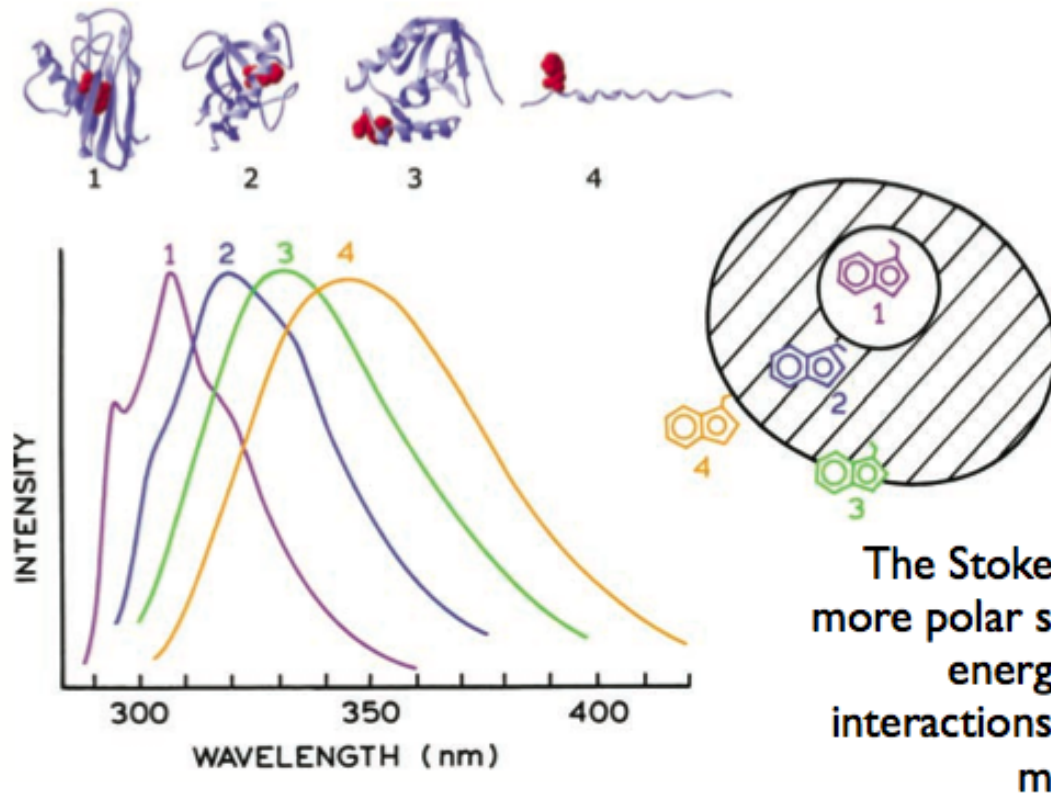
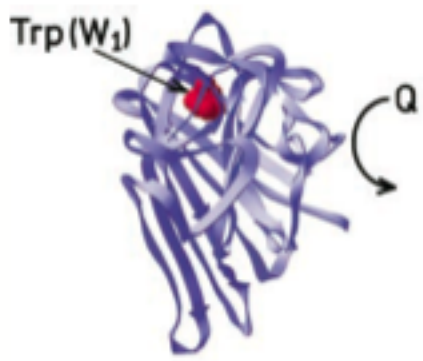

Figure 16.11. Effect of tryptophan environment on the emission spectra. The emission spectra are those of apoazurin Pfl, ribonuclease T₁, staphylococcal nuclease, and glucagon, for 1 to 4, respectively. Revised from [59] and [60].

Quenching of tryptophan in proteins

Buried (blue-shifted) tryptophan is less accessible to polar quenching agents, so the quenched spectrum is blue-shifted.



Buried Tryptophan

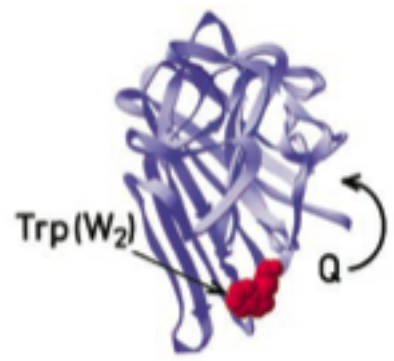

Surface Tryptophan

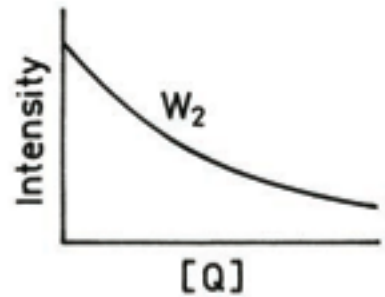
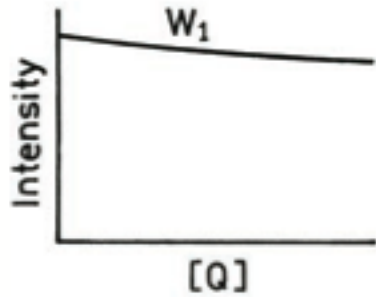
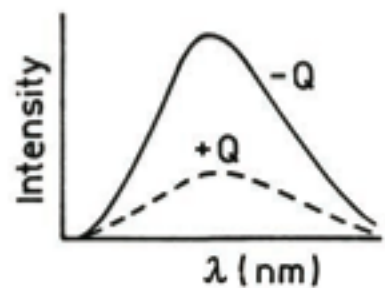
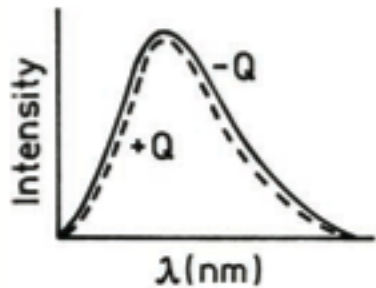
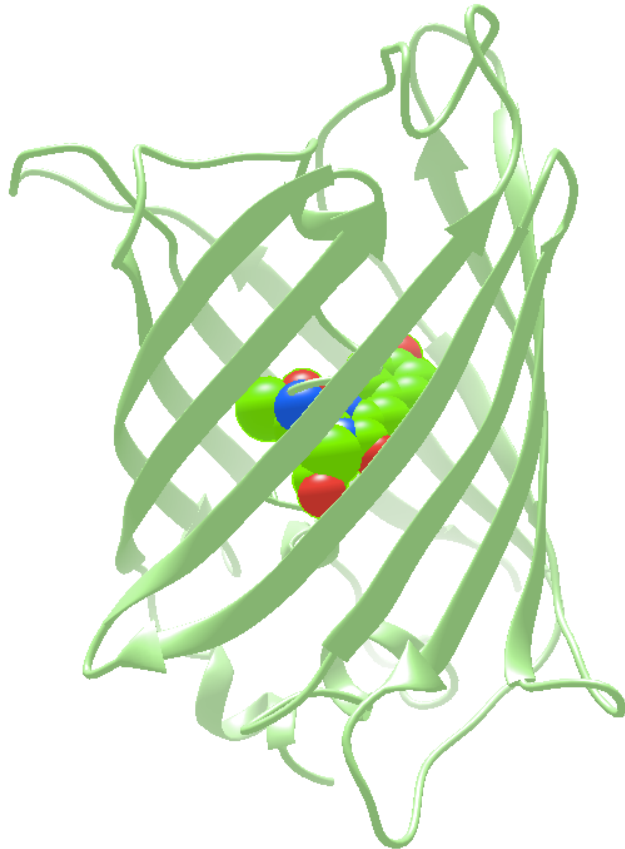
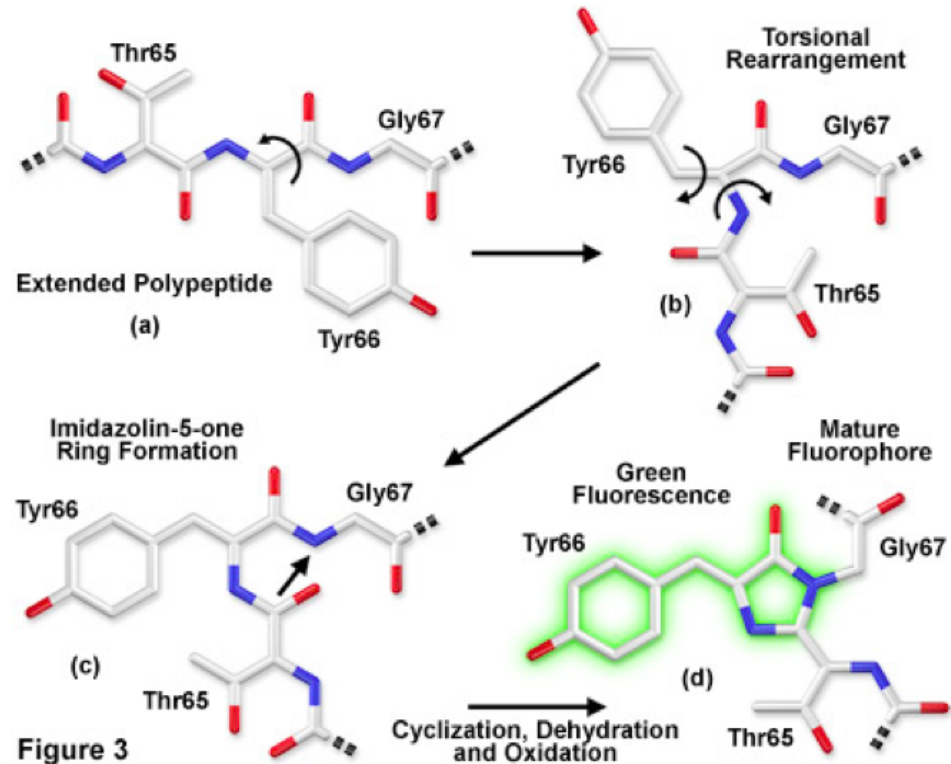

Figure 16.30. Collisional quenching of buried (W_1) and surface accessible (W_2) tryptophan residues in proteins.

Green fluorescent protein (GFP)



Maturation of the Enhanced Green Fluorescent Protein Chromophore



Modes of design-response

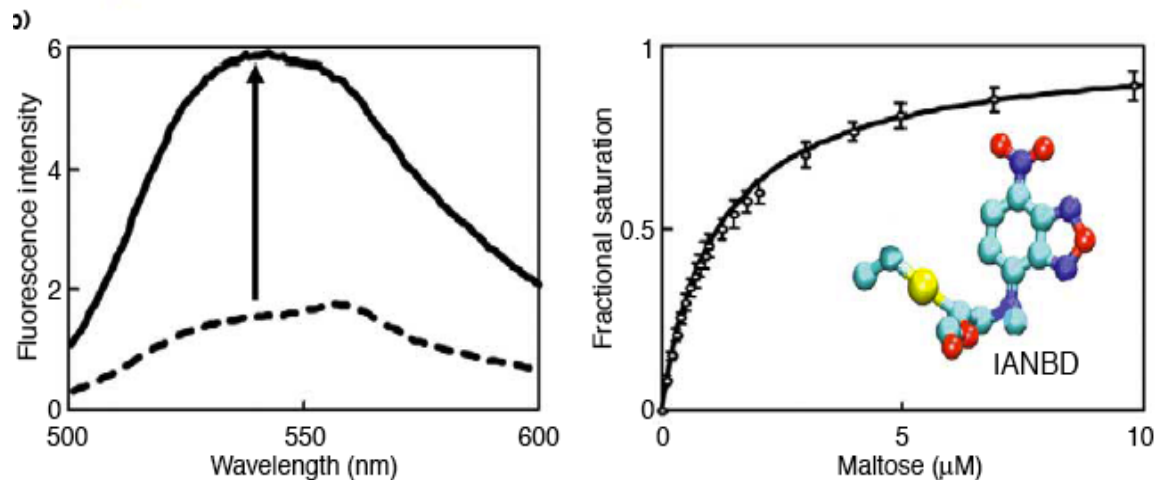
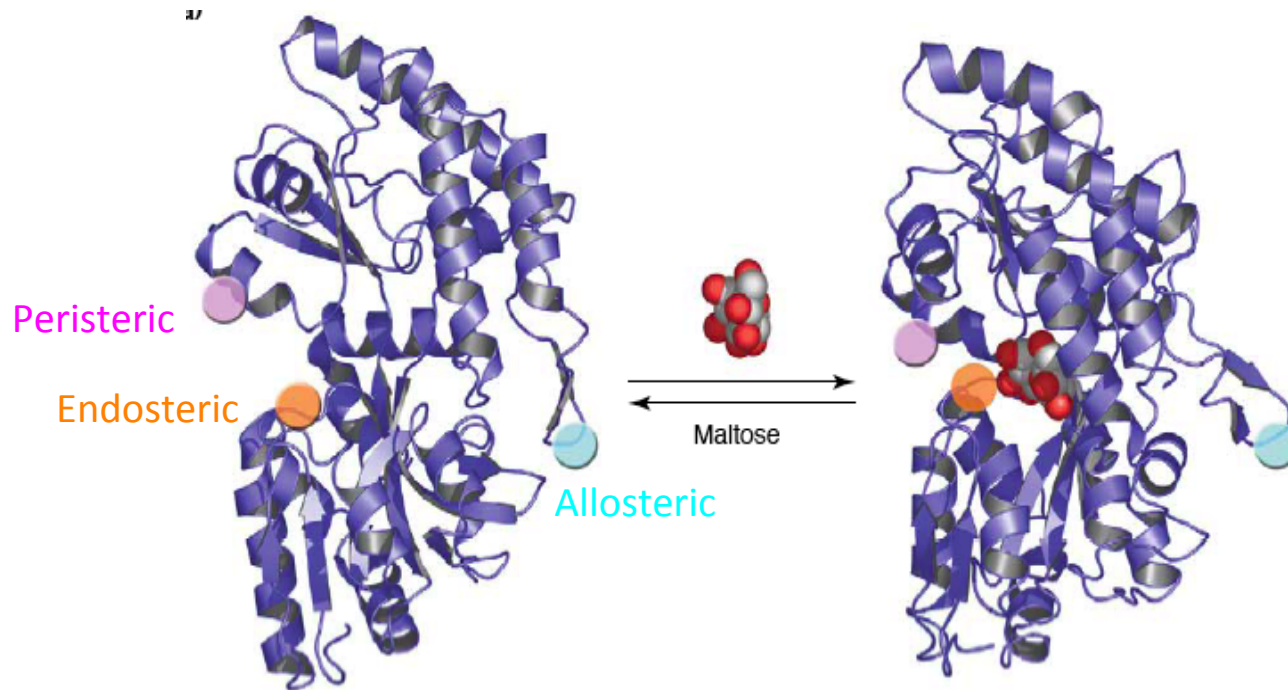

The MBP as biosensor

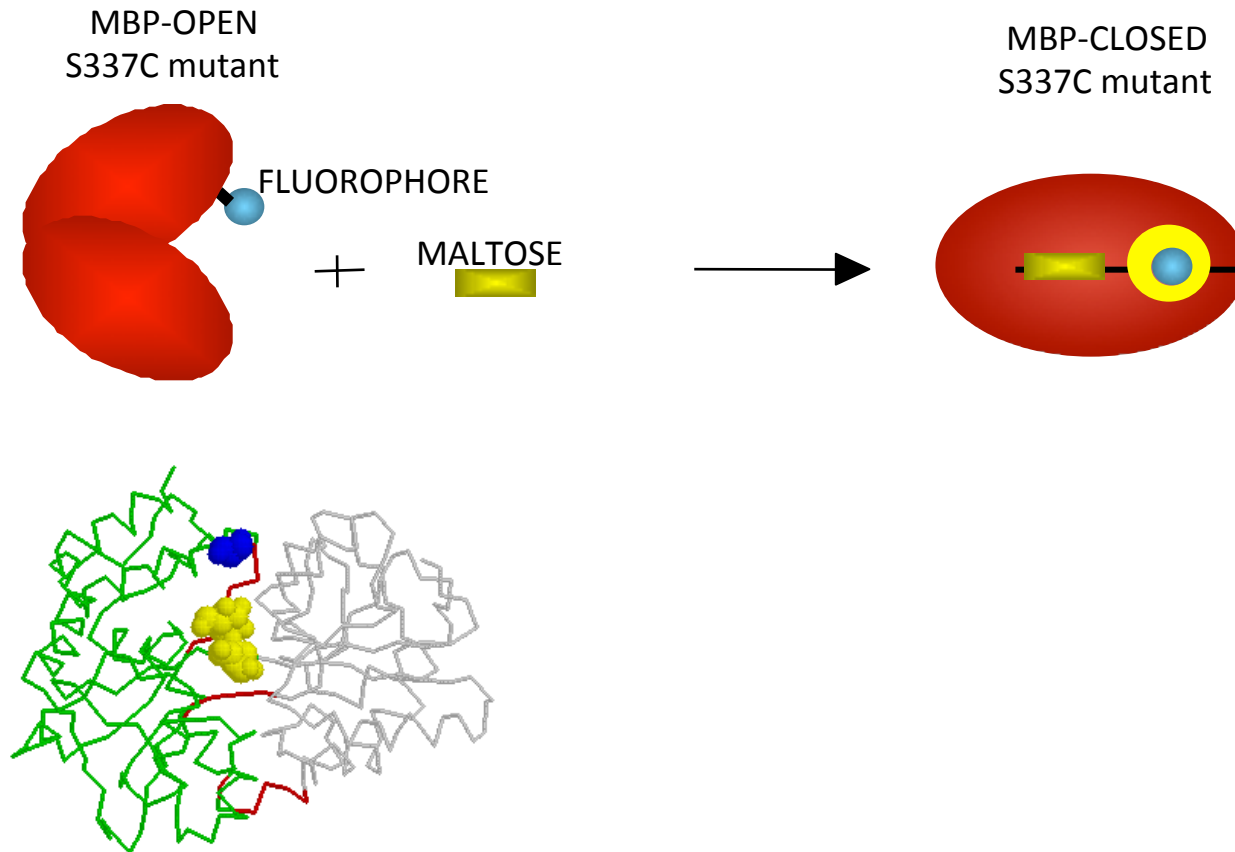

Fluorescence emission

IANBD^E ester

N-((2-(iodoacetoxy)ethyl)-N-methyl)-
amino-7-nitrobenz-2-oxa-1,3-diazole

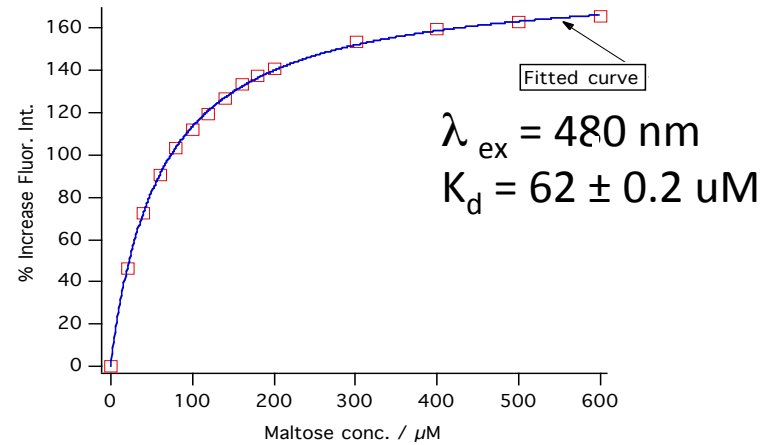
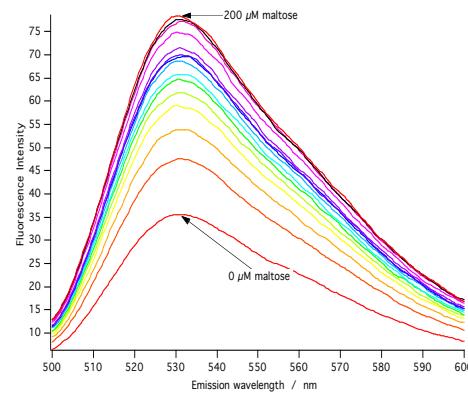
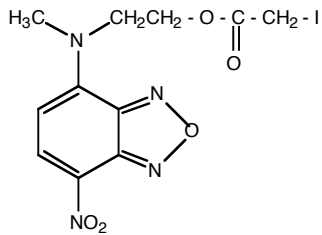

Acrylodan

6-acryloyl-2-dimethylamino-
naphthalene

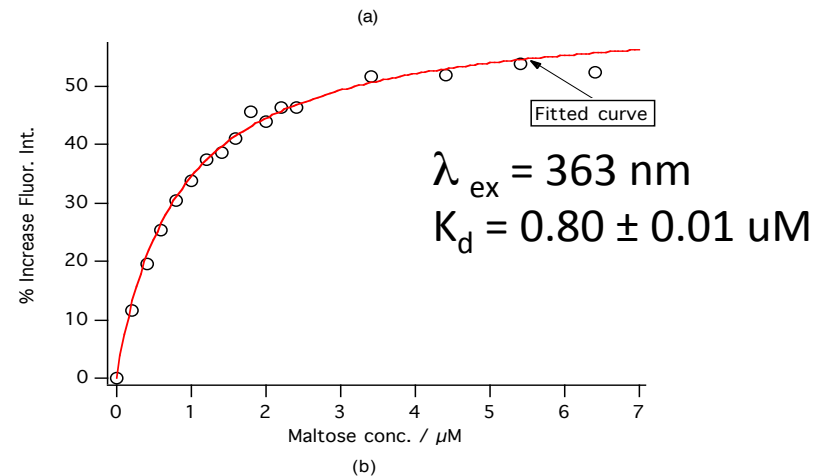
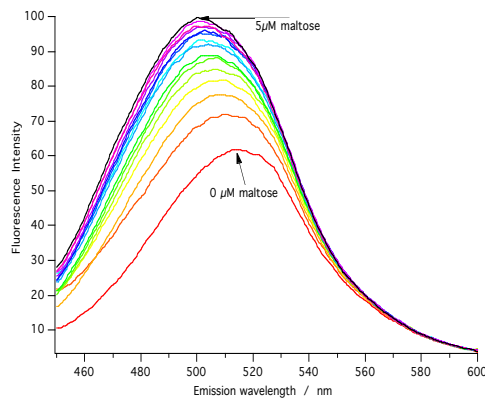
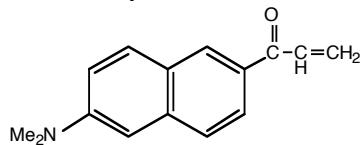

1.3 τ , lifetime = emission as a function of time

- When there is more than one fluorophore in a protein, their environments may be different, but their fluorescence emissions will not be resolved
- They very likely may have different lifetimes τ , and these can be studied with lifetime measurements
- Lifetime measurements are made possible by applying short pulses of light, 1 ns, and monitor the emission $S(t)$ as a function of time.
- $S(t)$ is related to the initial emission intensity $S(0)$ following a pulse by:

$$S(t) = S(0)e^{-t/\tau}$$

- When there are two or more fluorophores, it is possible to fit the decay emission to two or more exponentials that give two or more τ
- A distribution analysis of lifetimes gives info on flexibility

Time-resolved fluorescence spectroscopy

- It provides fluorescence intensity decay in terms of lifetimes

Advantages:

- enhance the discrimination among fluorophores (overlapping emission spectra)
- sensitive to various parameters of the biological microenvironment

The fluorescence lifetime can probe

a) local environment

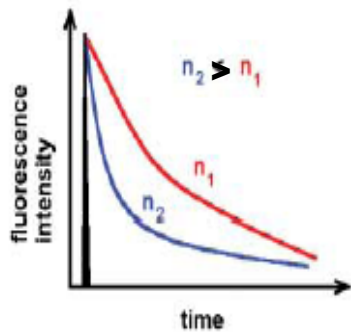
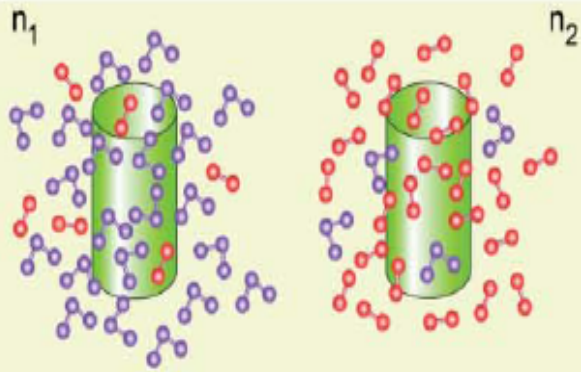

b) FRET

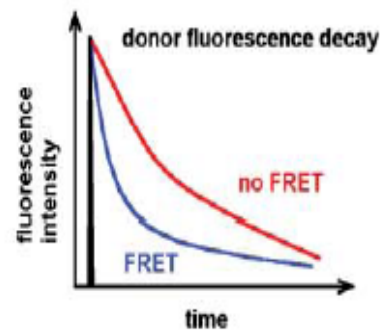
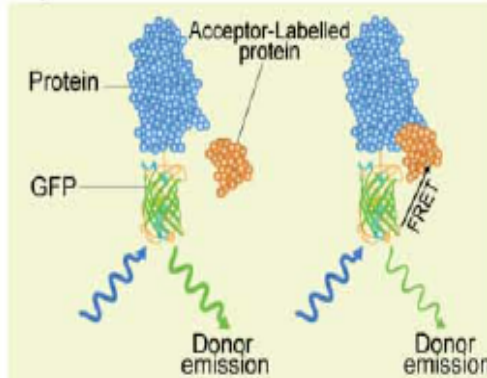

c) rotational mobility

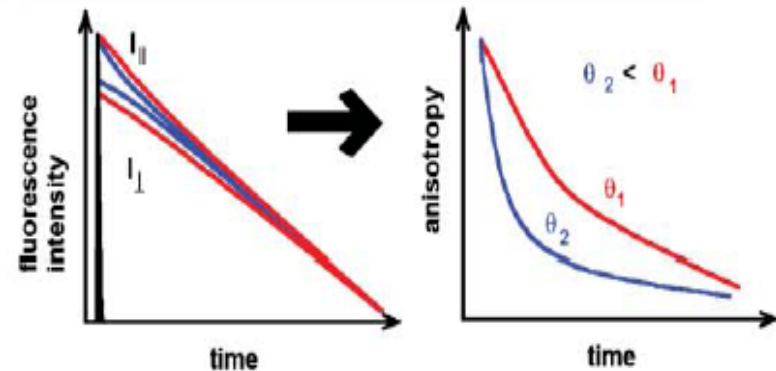
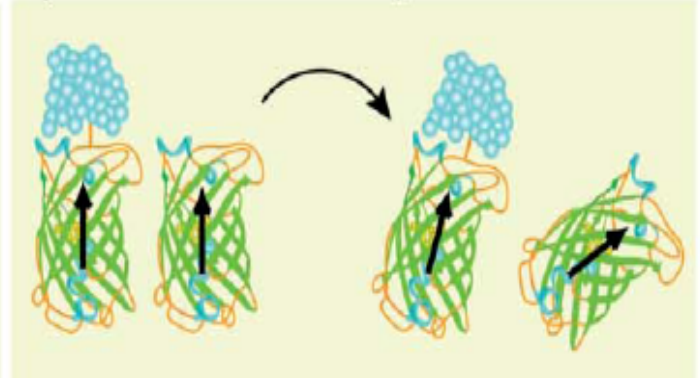

Fluorescence anisotropy is the phenomenon where the light emitted by a fluorophore has unequal intensities along different axes of polarization.

Time resolved fluorescence

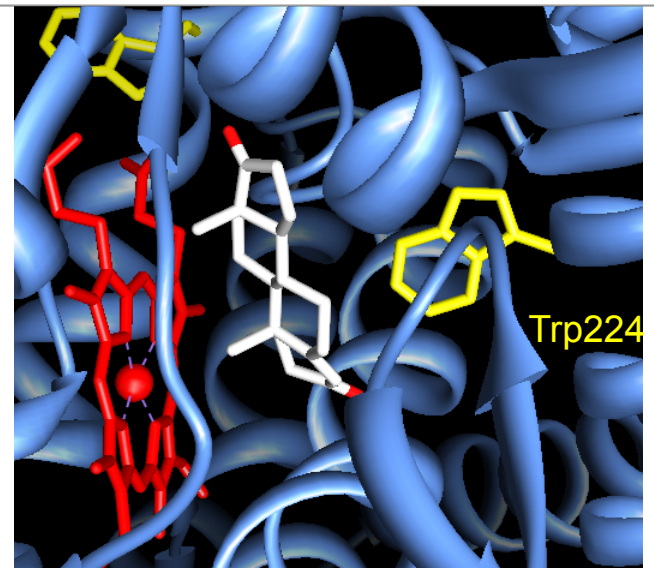
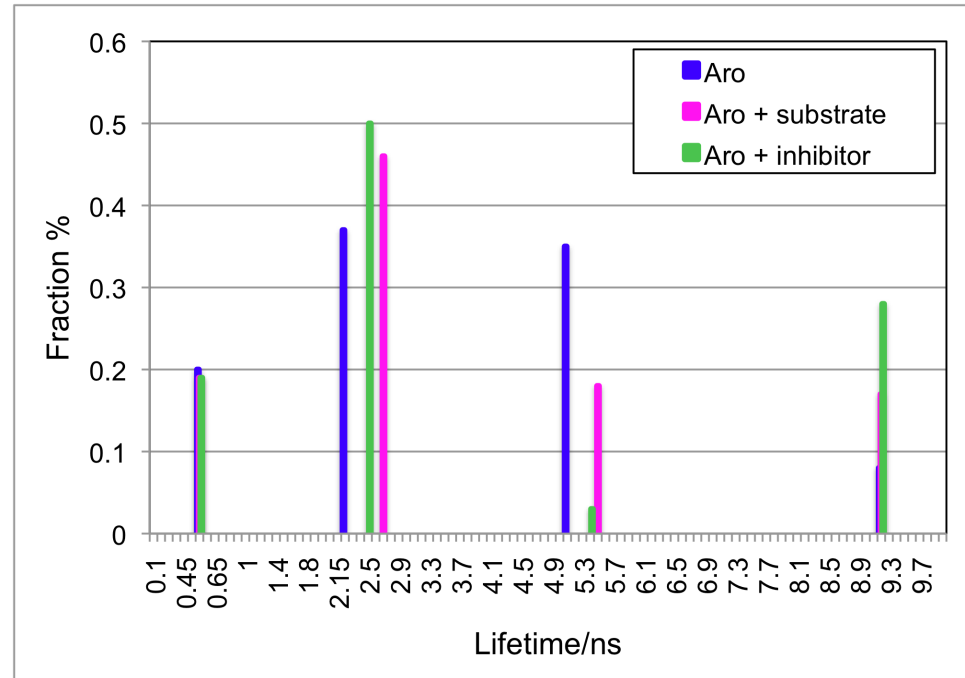
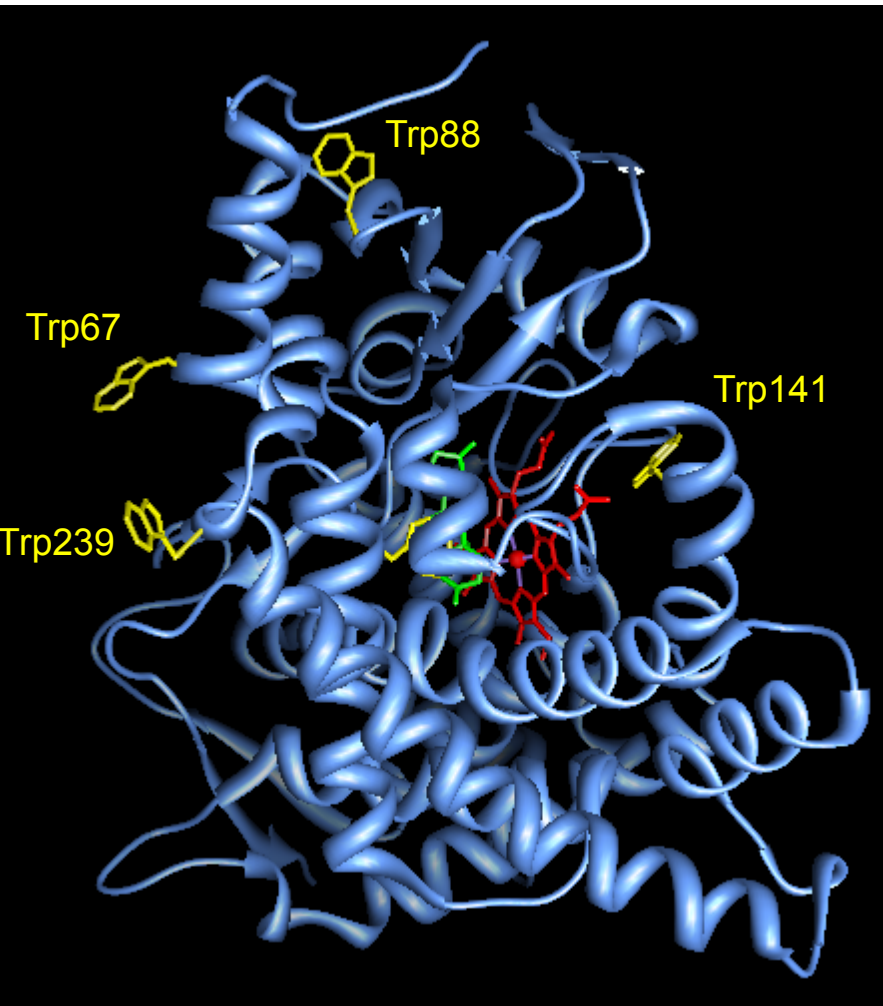

Time resolved fluorescence

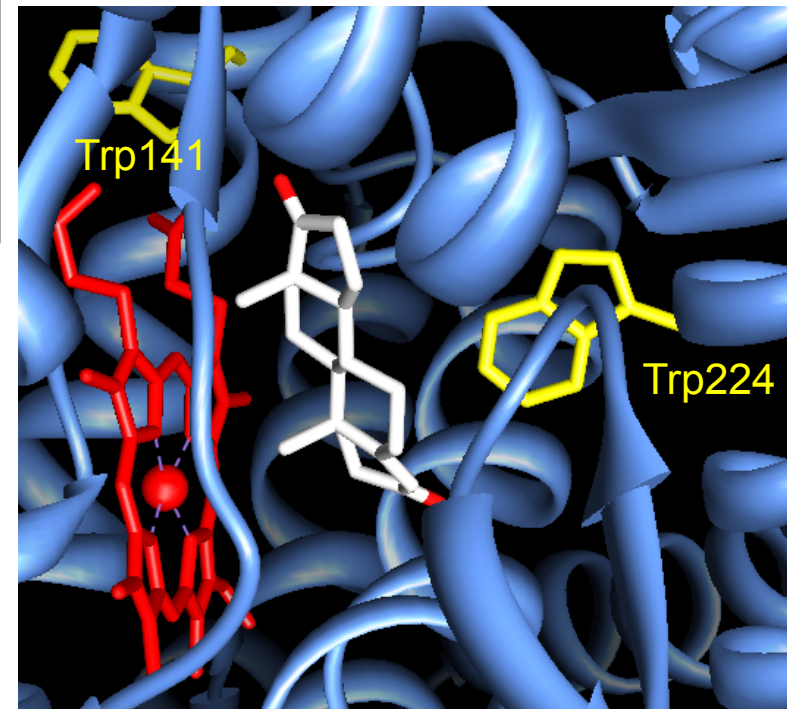
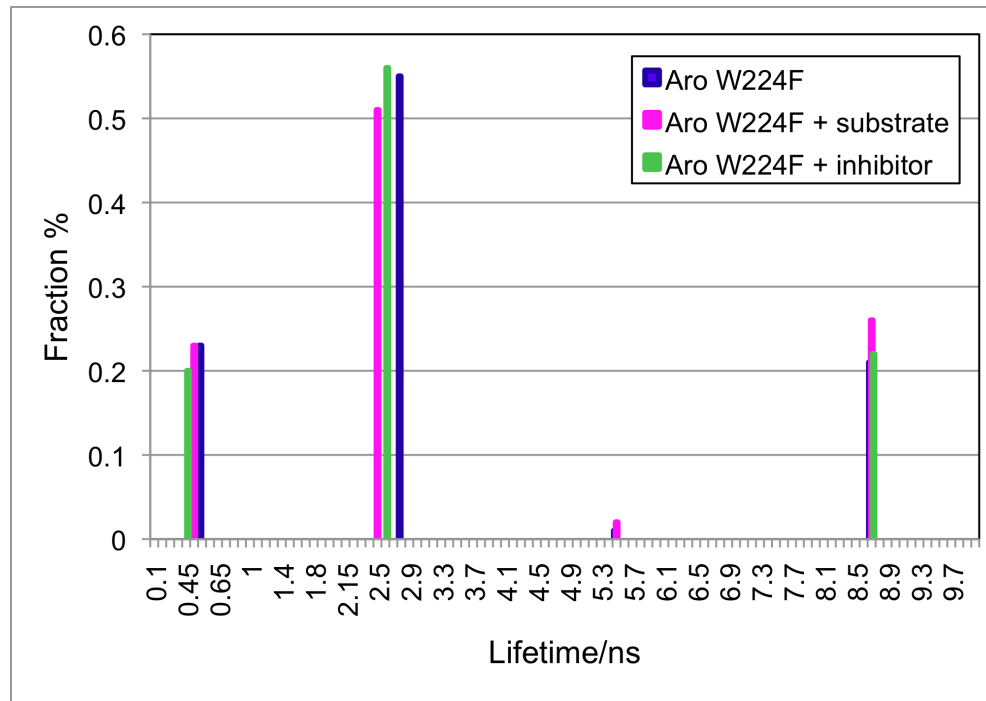

2. Influence of molecular dynamics

- Fluorescence detects tumbling or collisions that occur in the 10^{-9} s.
- Quenching = shortening of fluorescence lifetime by collisions that depopulate the excited state.
- Quenchers can be also paramagnetic molecules, inorganic ions such as Cs^- or I^- or even the O_2 dissolved in the sample.
- Dynamic quenching refers to the collisions by encounters during the excitation-emission process
- Static quenching refers to the complex quencher-fluorophore formed prior to excitation

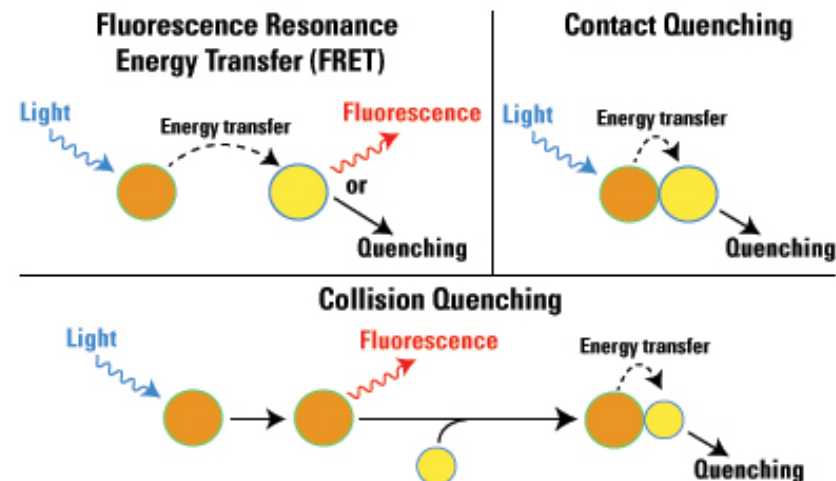

3. Distances between fluorophores: resonance energy transfer

- This is possible when energy is transferred from the singlet excited state of a donor to the singlet excited state of an acceptor that relaxes back the donor.
- This can only happen when the energy separations in each case match, i.e. are in resonance:

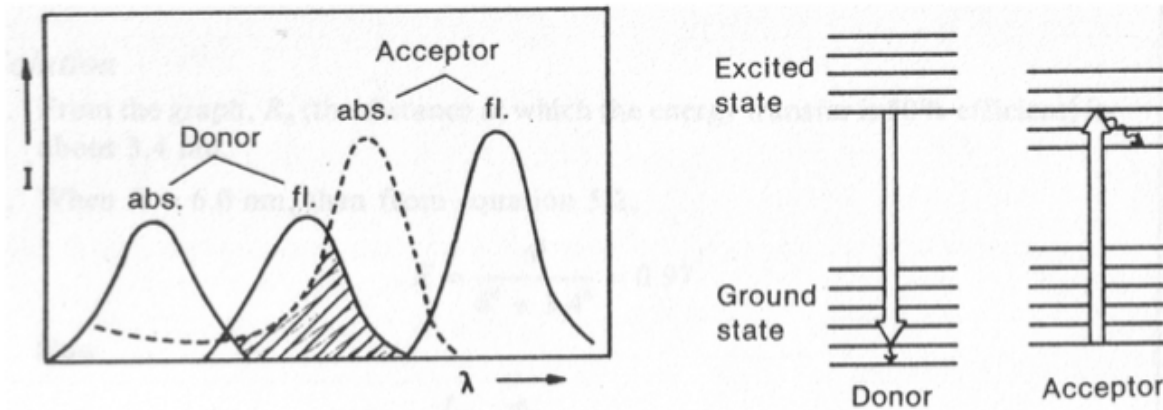

Imaging protein interaction by FRET

fluorescence / Förster resonance energy transfer occurs at close proximity of donor and acceptor, $<8\text{nm}$

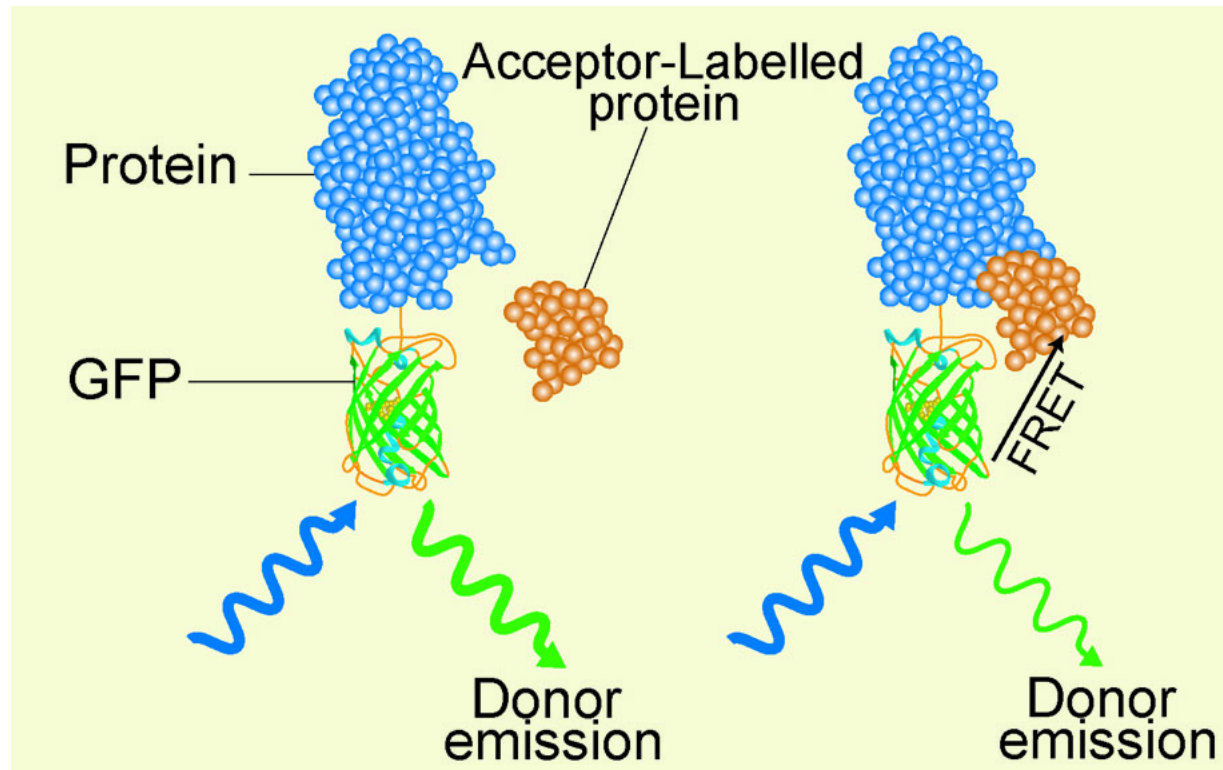

donor
fluorescence
lifetime
shortened

Förster Resonance Energy Transfer Jablonski Diagram

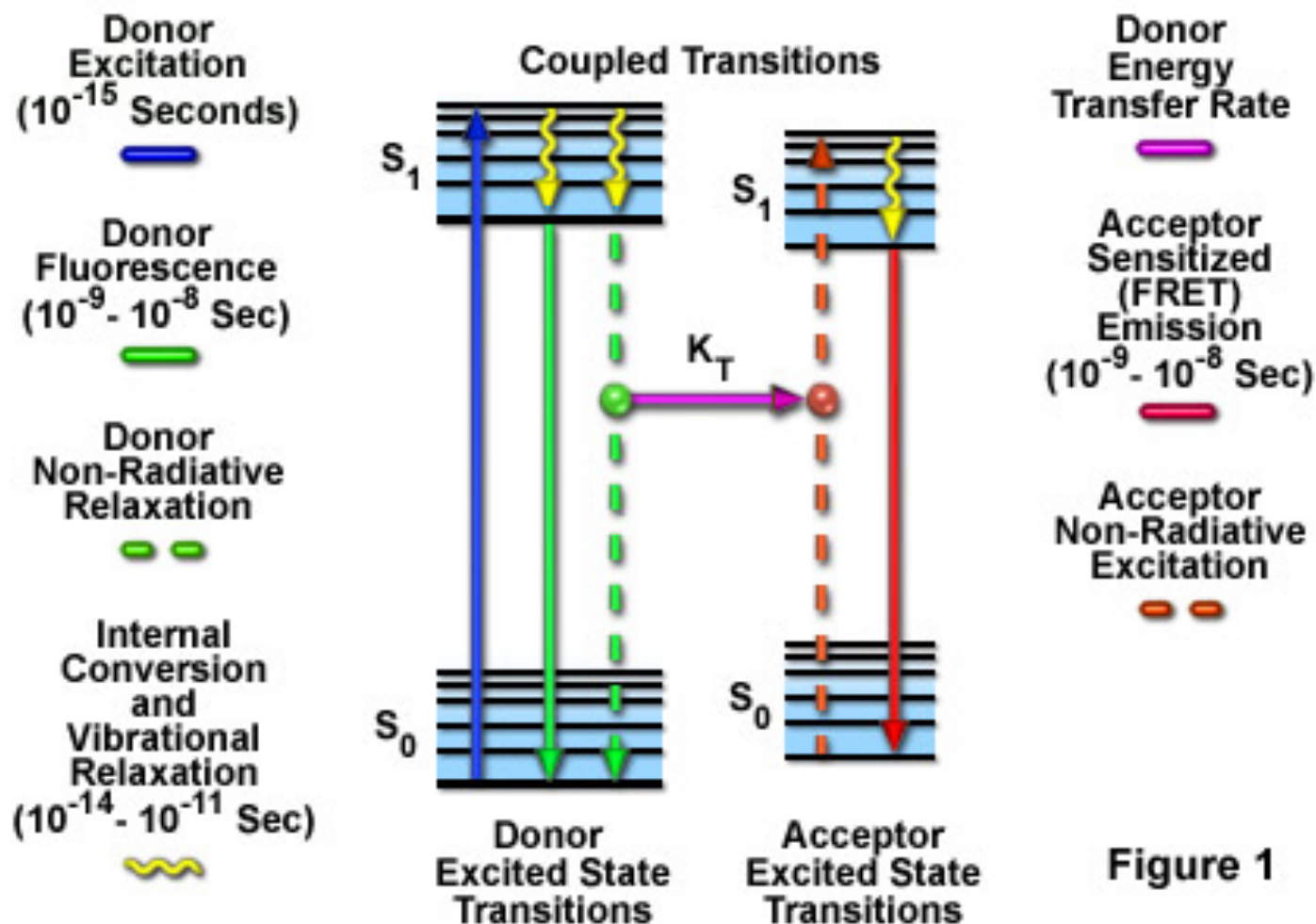
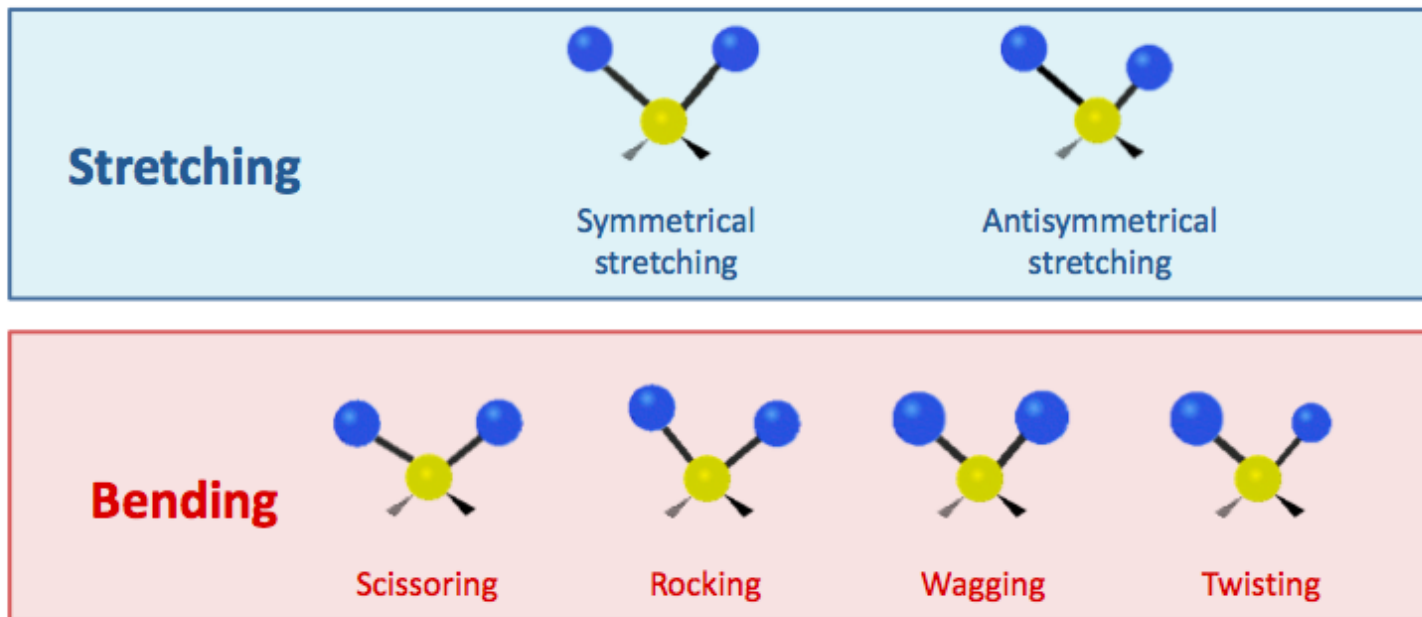

Figure 1

Infrared Spectroscopy

Infrared spectroscopy measures transitions between vibrational states of molecules which are induced by irradiating the sample with infrared light



Infrared Spectroscopy

Most of the chemical compounds show infrared spectra with sharp peaks at certain frequencies which correspond to the vibrational frequencies of specific functional groups or bonding arrangements, and these can be used as fingerprints for identifying compounds

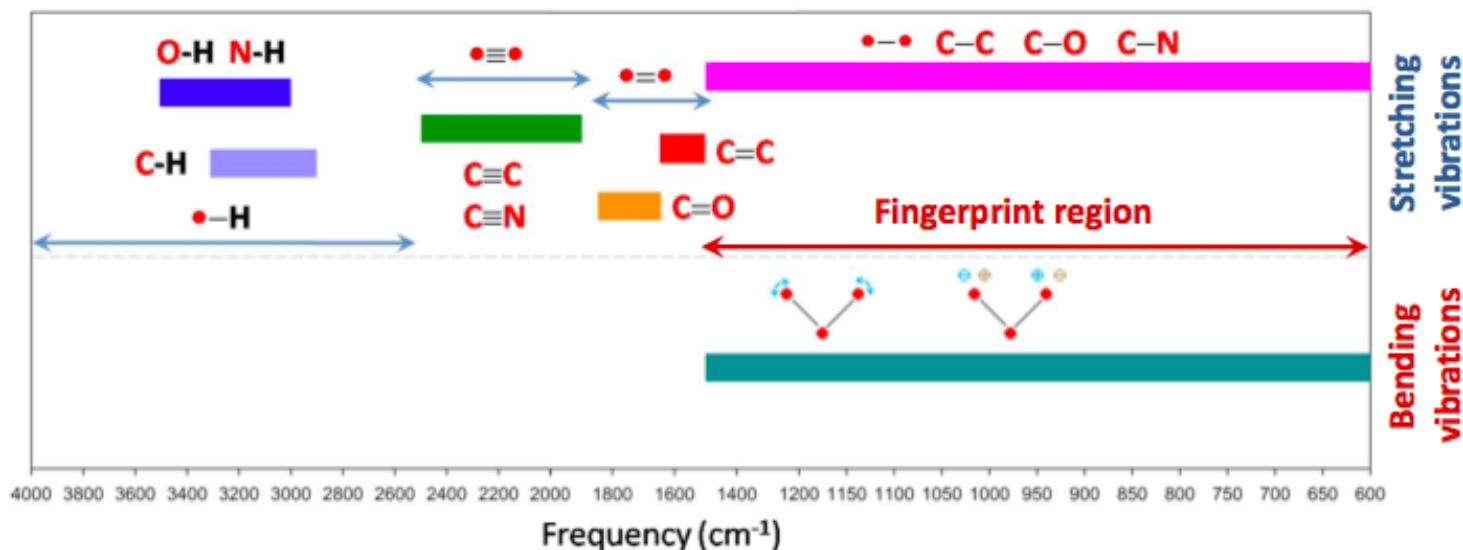

Fourier Transform Infrared Spectrophotometer

*A method for measuring all of the infrared frequencies
simultaneously, rather than individually*

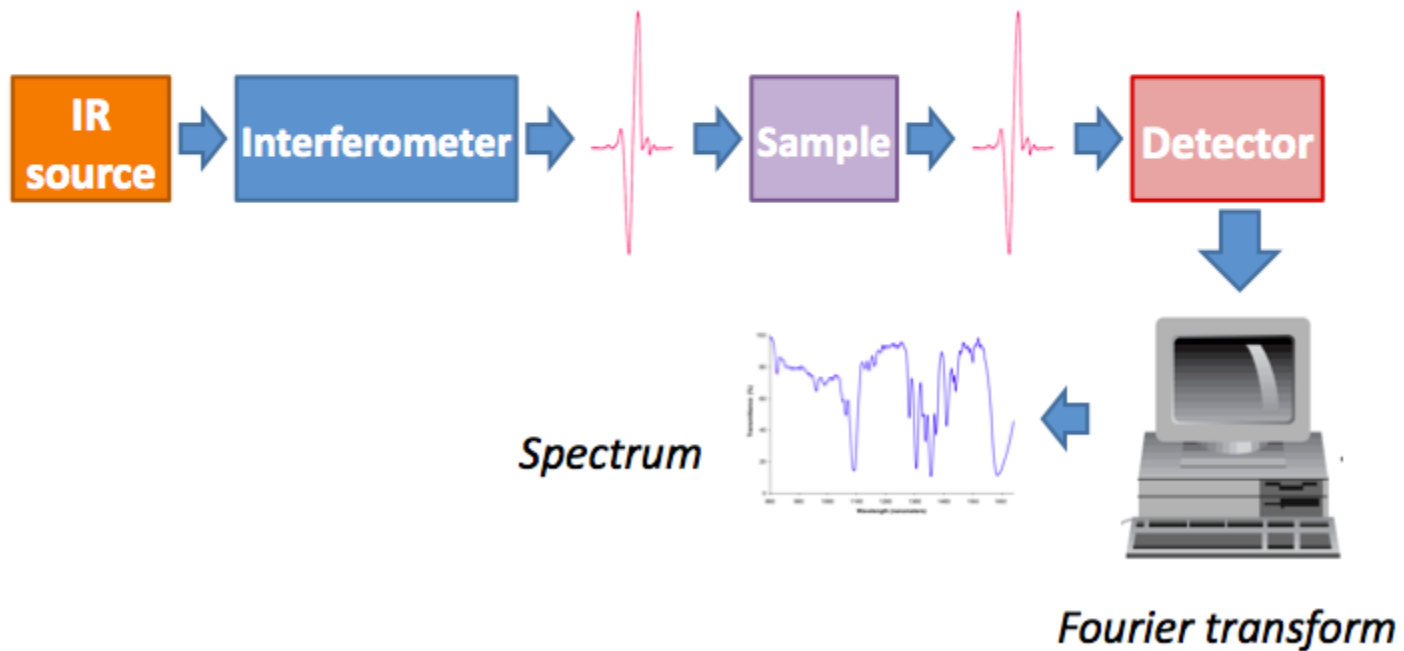

FTIR analysis of protein structure

Amide I vibration

1600-1700 cm^{-1}

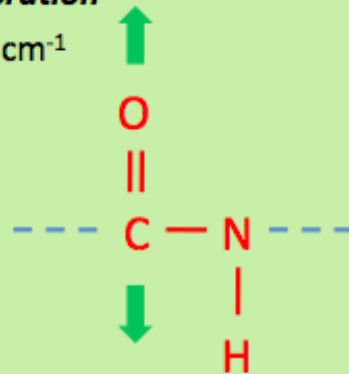

Amide II vibration

$\sim 1550 \text{ cm}^{-1}$

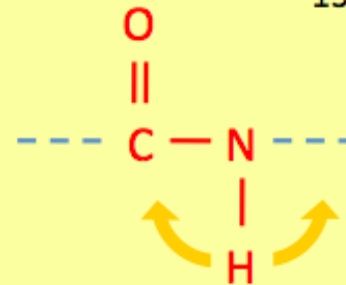

Amide III vibration

1200-1400 cm^{-1}

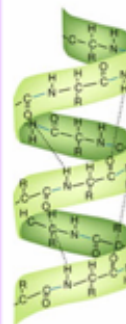
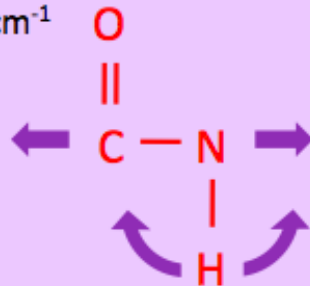

Because these bonds are involved in the hydrogen bonding that generate secondary structures, the locations of the Amide bands are sensitive to the secondary structure content of a protein

FTIR analysis of protein structure

Amide I band

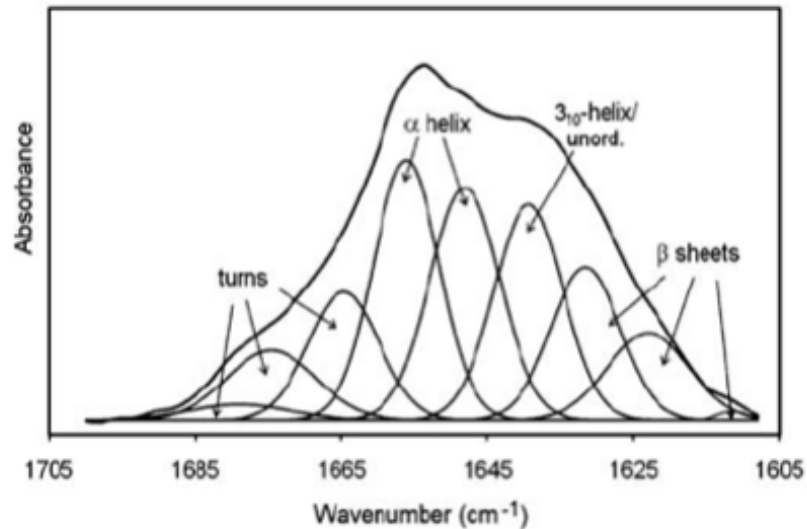
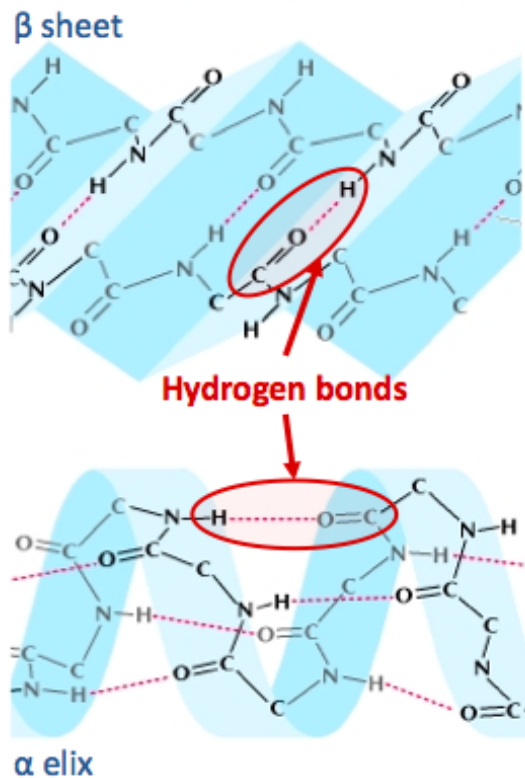

Secondary structure composition is commonly estimated from the relative areas of the single bands

FTIR analysis of protein structure

Studies with proteins of known structure have been used to correlate systematically the shape of the Amide I band to secondary structure

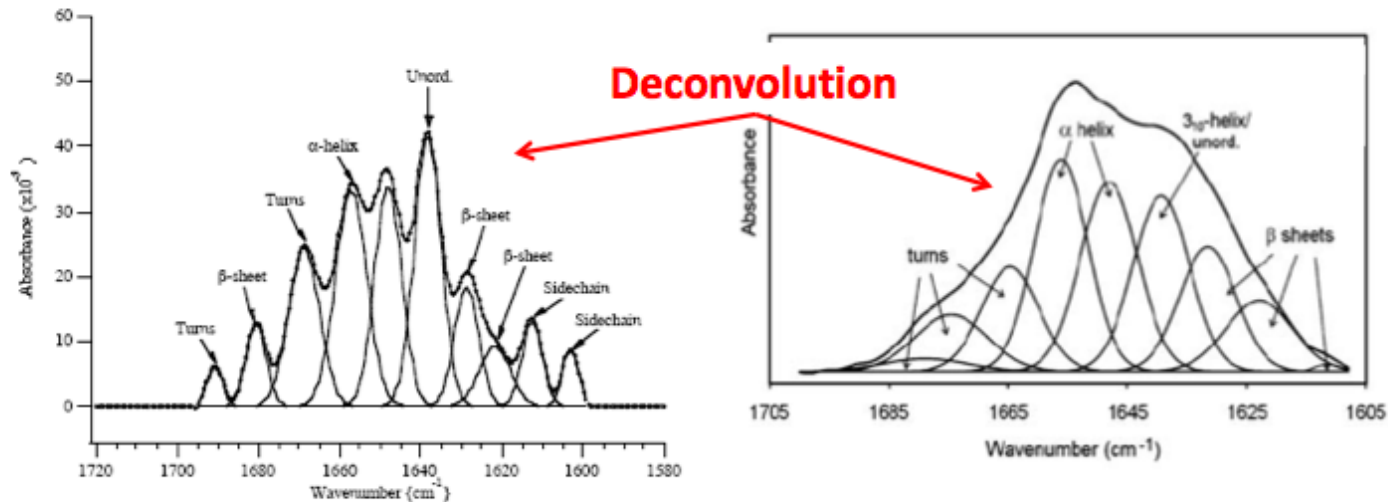

Amide I band

Secondary structure	Band position in $^1\text{H}_2\text{O}/\text{cm}^{-1}$		Band position in $^2\text{H}_2\text{O}/\text{cm}^{-1}$	
	Average	Extremes	Average	Extremes
α -helix	1654	1648–1657	1652	1642–1660
β -sheet	1633	1623–1641	1630	1615–1638
β -sheet	1684	1674–1695	1679	1672–1694
Turns	1672	1662–1686	1671	1653–1691
Disordered	1654	1642–1657	1645	1639–1654

A. Barth, C. Zscherp (2002) *Quart Rev Biophys*

ATR-FTIR spectroscopy: secondary structure determination

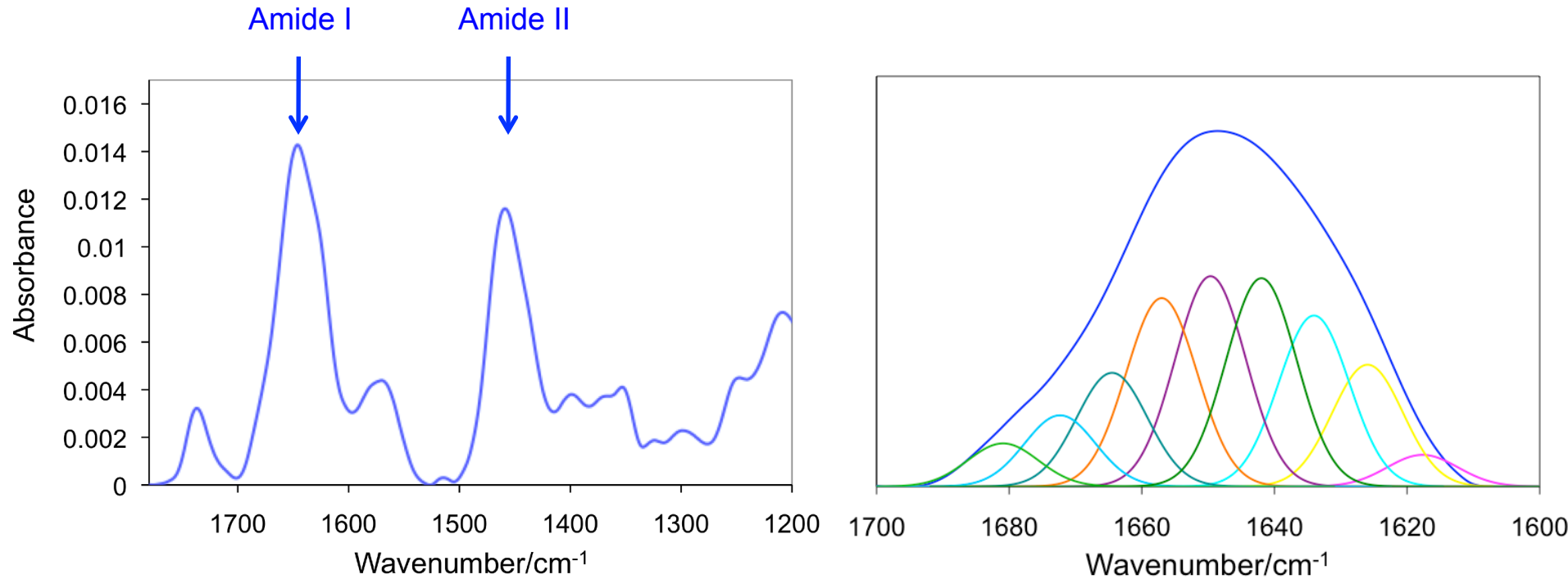

	β -sheet	s.d.	3_{10} + random	s.d.	α -helix	s.d.	β -turn	s.d.
Aro	25.76	1.20	15.66	5.50	37.05	2.60	21.54	2.85
Aro + sub	25.34	4.50	17.64	1.70	38.28	3.90	18.74	1.70
Aro + ini	22.25	4.35	16.76	1.58	37.73	5.52	23.26	2.93

Protein folding

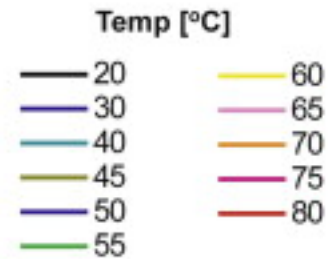
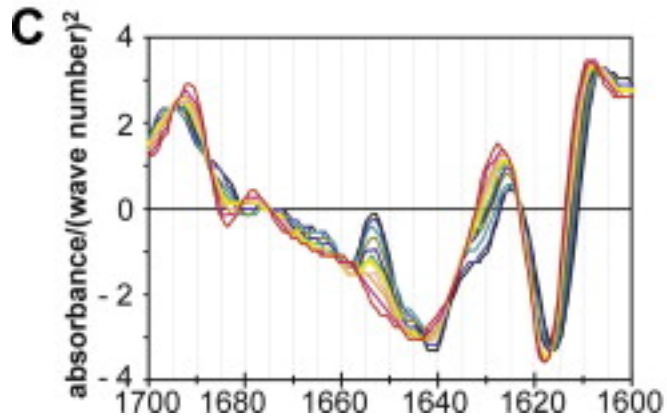
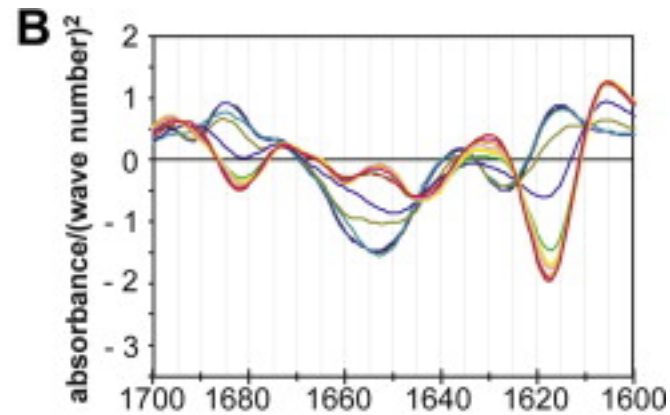
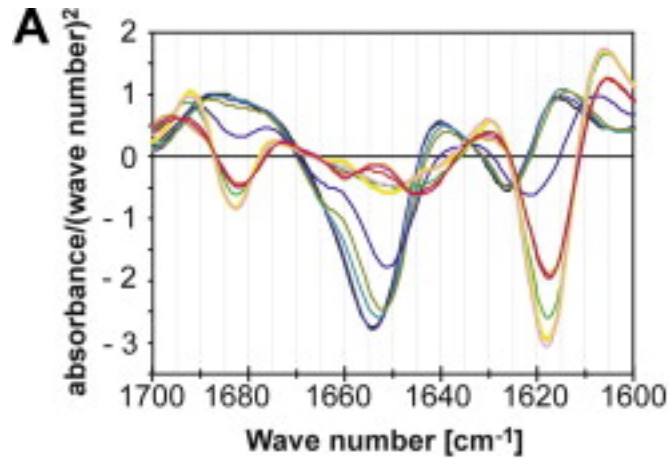

Protein flexibility: H/D exchange

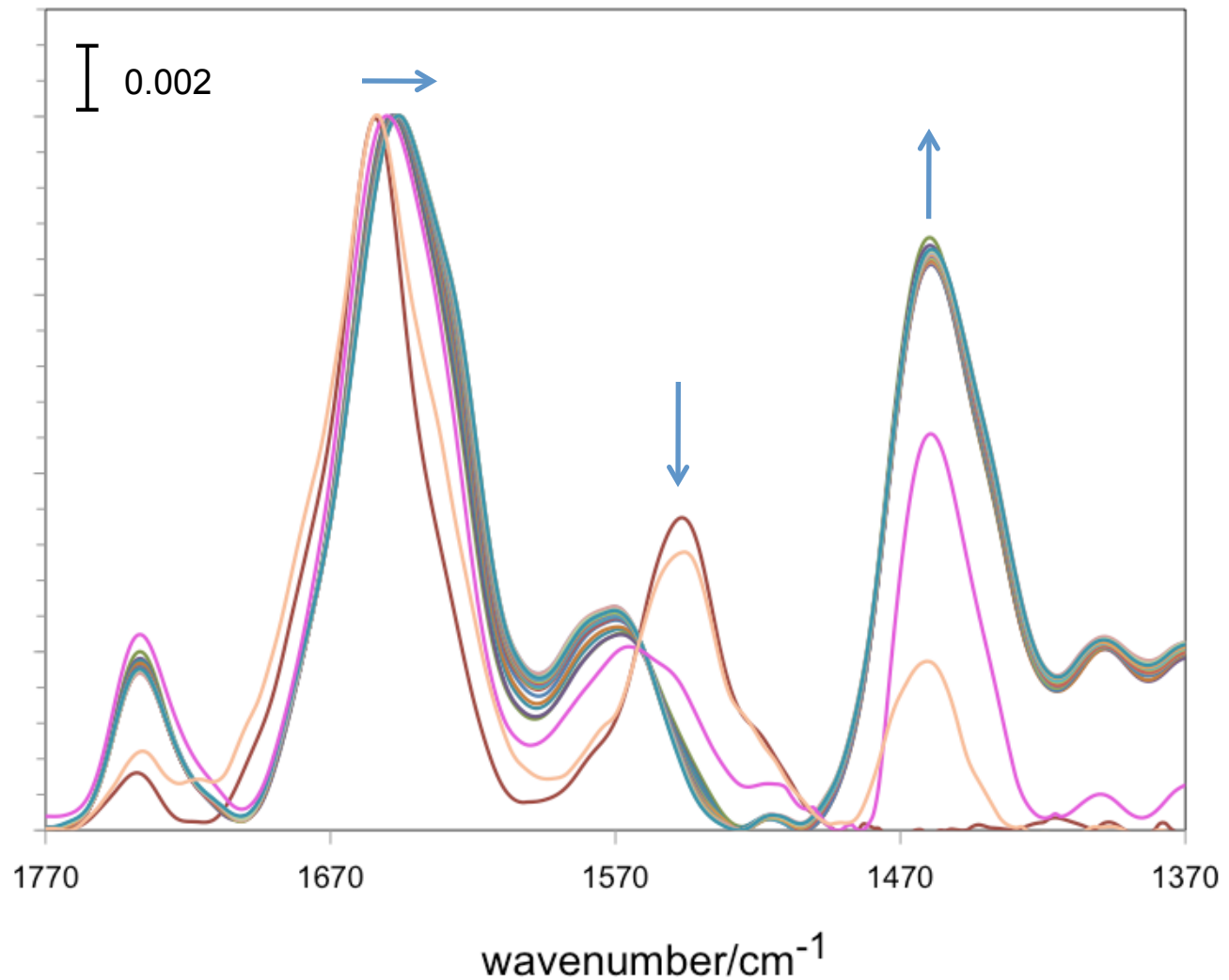

Second derivative FTIR spectra

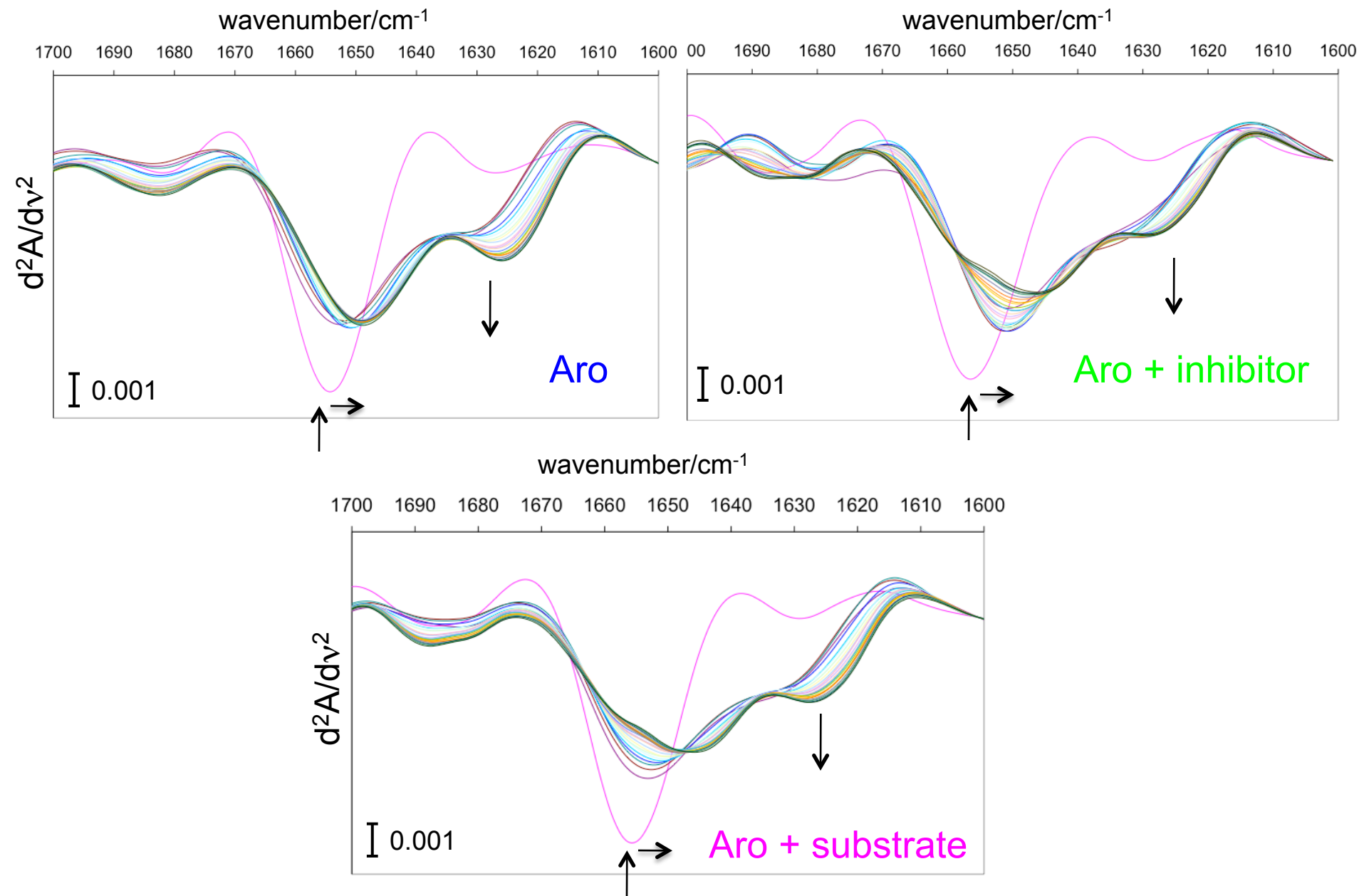

Kinetics of α -helices H/D exchange

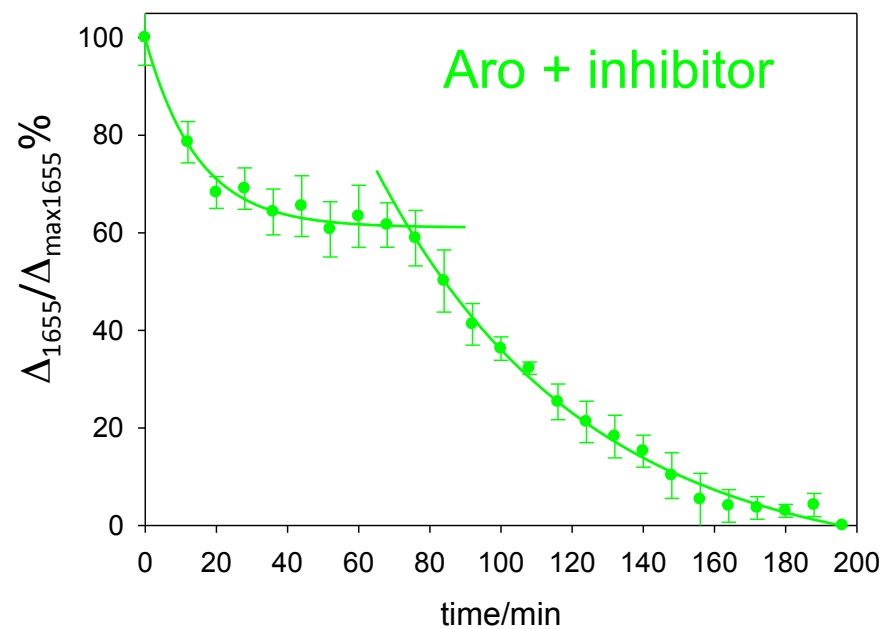
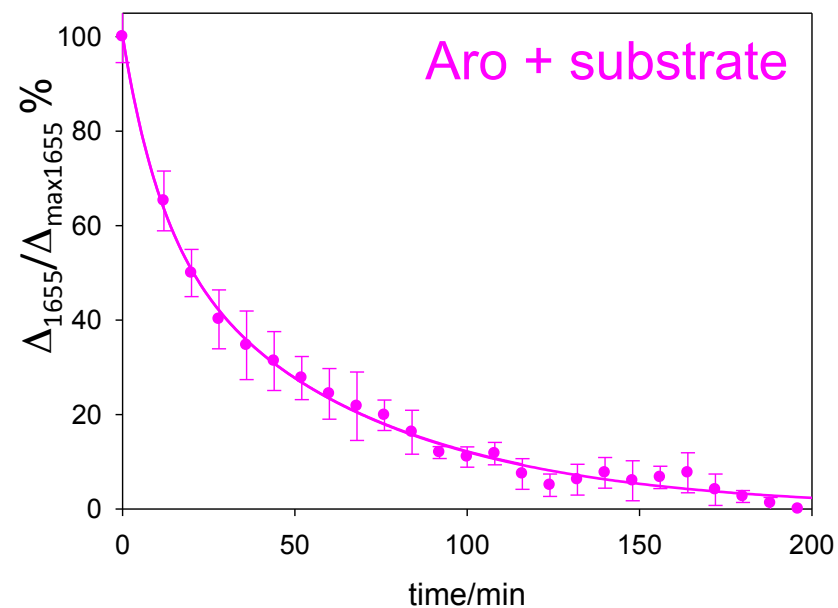
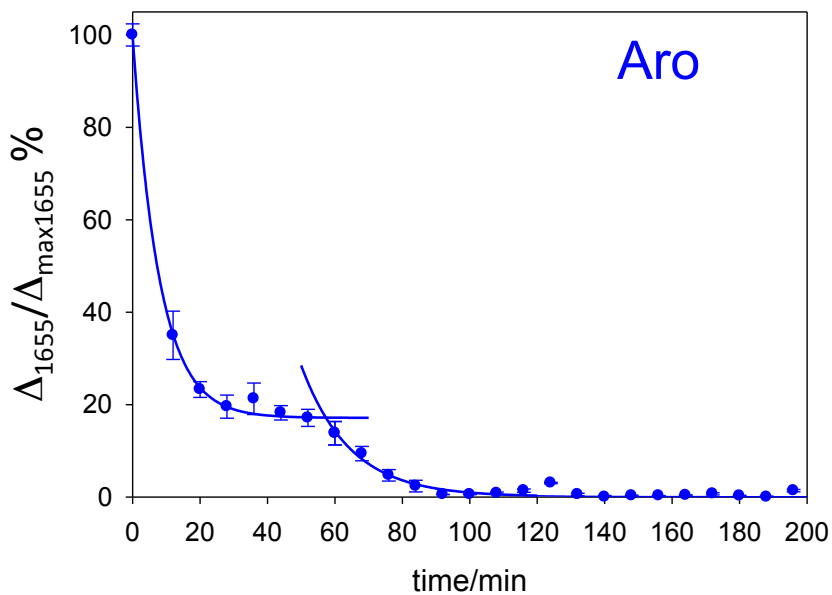

	K_1 (min^{-1})	s.d.	K_2 (min^{-1})	s.d.
Aro	0.127	0.010	0.069	0.013
Aro+sub	0.091	0.019	0.016	0.001
Aro+inhib	0.068	0.009	0.017	0.002

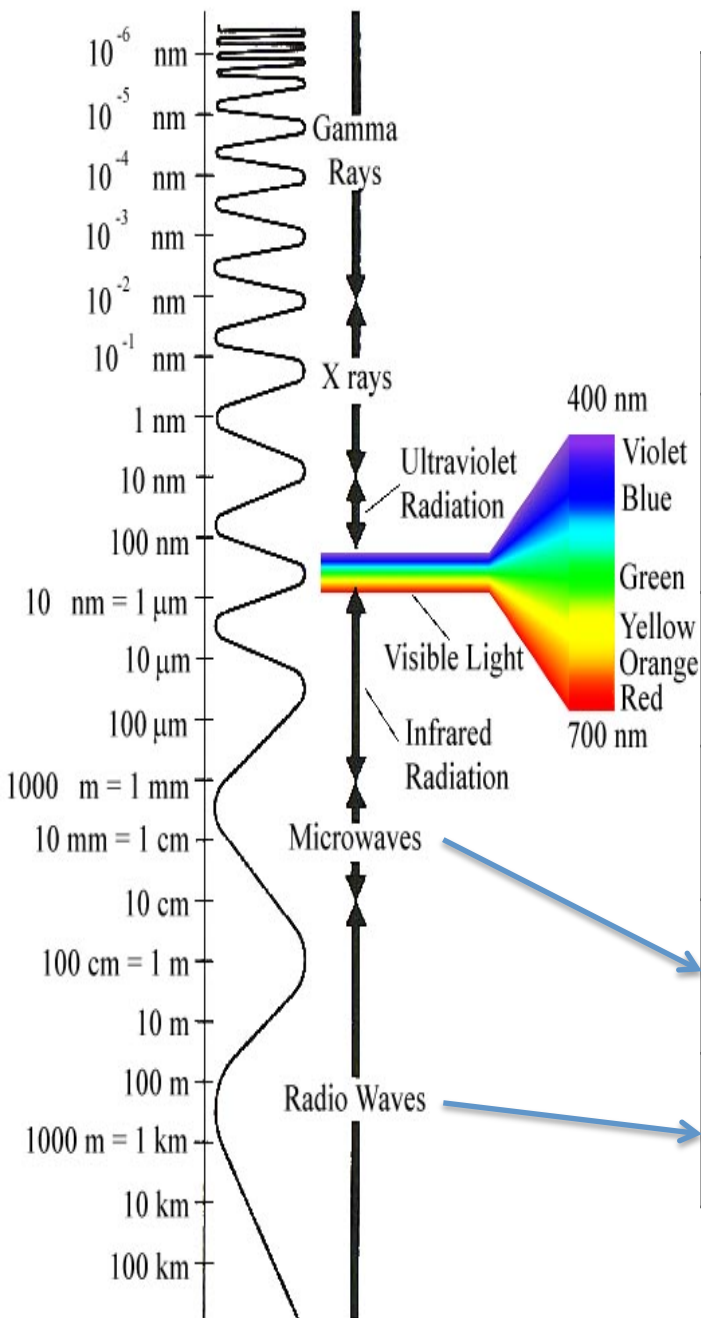

Technique	Structural information
X-ray crystallography	3D- structure
Absorption, circular dichroism, fluorescence spectroscopy	Secondary structure, changes in secondary and tertiary structure, dynamics
Visible absorption and circular dichroism	Presence of cofactors and environment
Infrared spectroscopy	Secondary structure, changes in secondary and tertiary structure, dynamics
Electronic magnetic resonance	Presence of paramagnetic centers and monitoring their environment
Nuclear magnetic resonance (NMR)	3D. Structure, dynamics, motions